

# MEDIA UNIT

Stock number: 9199/9234-25

Thank you for purchasing this product. Please read the instructions carefully before use to ensure safe and satisfactory operation of this product.

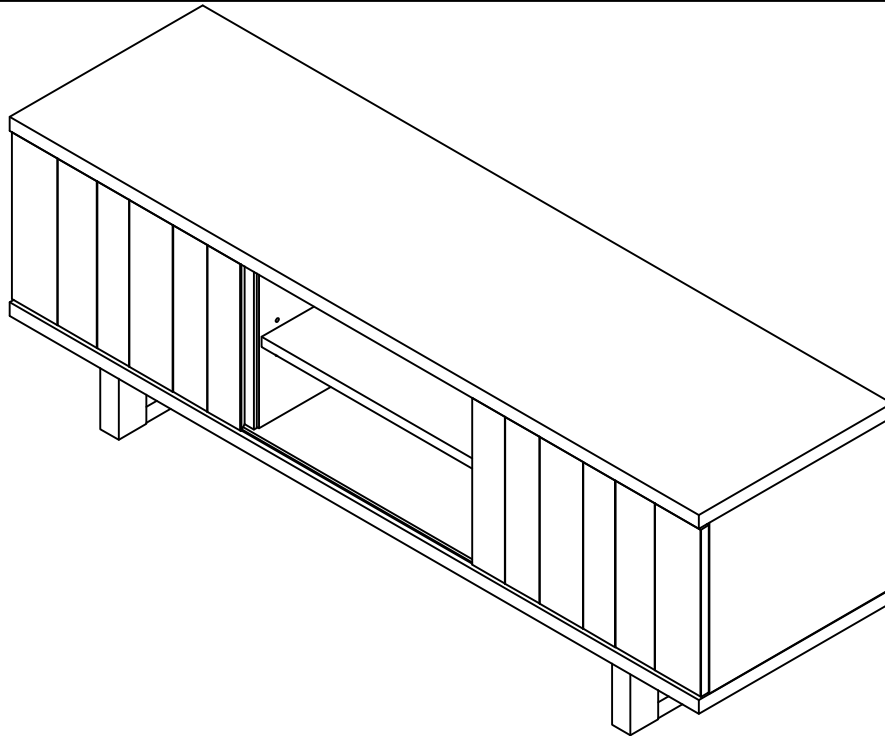

## Pre-assembly preparation

Please ensure instructions are read in full before attempting to assemble this product.

## Necessary Tools :

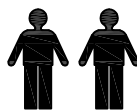

(Included)

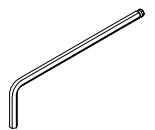

Please check the pack contents before attempting to assemble this product. A full checklist of components is given in this leaflet. If any components are missing, please contact the retailer from whom you bought this product.

This product takes approximately **30 MINUTES** to assemble with **2 PEOPLE**.

All assembly should be performed on a flat, stable, clean and soft surface.

This product is **HEAVY**, it should be assembled as near as possible to the point of use. **TAKE CARE WHEN LIFTING** to avoid personal injury and (or) damage to the product.

The fitting pack contains **SMALL ITEMS** which should be **KEPT AWAY FROM YOUNG CHILDREN**.

**IMPORTANT:** Retain these instructions for future reference.

Page : 1

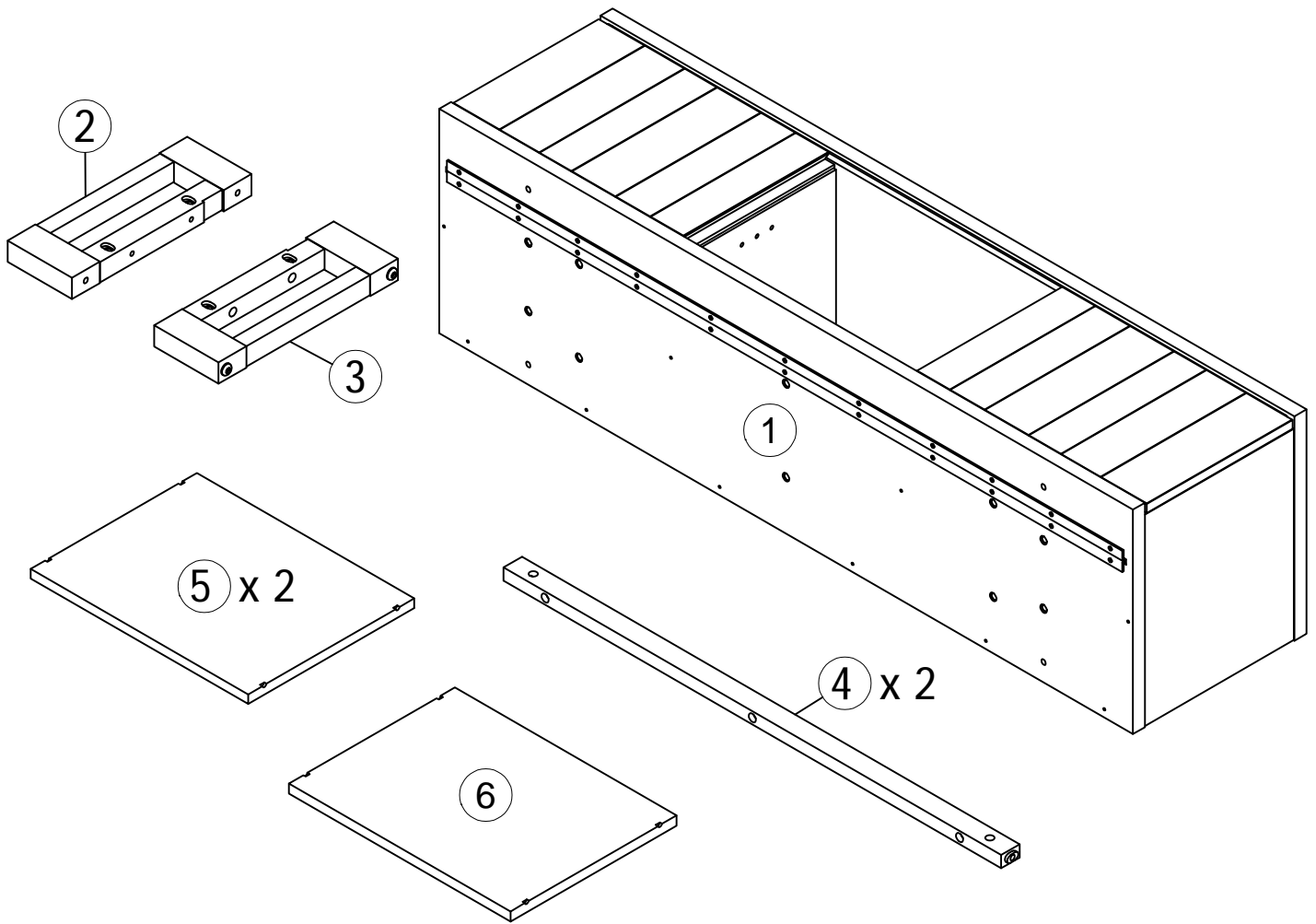

## Fittings and parts checklist

Item	Description	Qty.	Item	Description	Qty.
1	Top unit	x 1	4	Side apron	x 2
2	Leg frame left	x 1	5	Adjustable shelf A	x 2
3	Leg frame right	x 1	6	Adjustable shelf B	x 1
A	Wooden dowel Ø10 x 30mm	x 4	E	Allen key M4 x 30 x 110mm	x 1
B	Steel dowel Ø10 x 48.5mm	x 4	F	Hex head bolt M6 x 45mm	x 10
C	Grub screw M10 x 10mm	x 4	G	Shelf pin	x 12
D	Allen key M5 x 30 x 110mm	x 1			

# Step By Step Assembly Instructions

## Step 1

- 1.1 : Lay all parts on a flat, stable, clean and soft surface.
- 1.2 : Insert 4x wooden dowels (A) into the pre-drilled holes on leg frame left (2) & leg frame right (3) as shown.
- 1.3 : Attach 4x steel dowels (B) to leg frame left (2) & leg frame right (3) by screwing fittings (B) into the inset fittings that are located on part (2), (3) as shown. Ensure the holes on fittings (B) are facing the correct direction as per diagram.

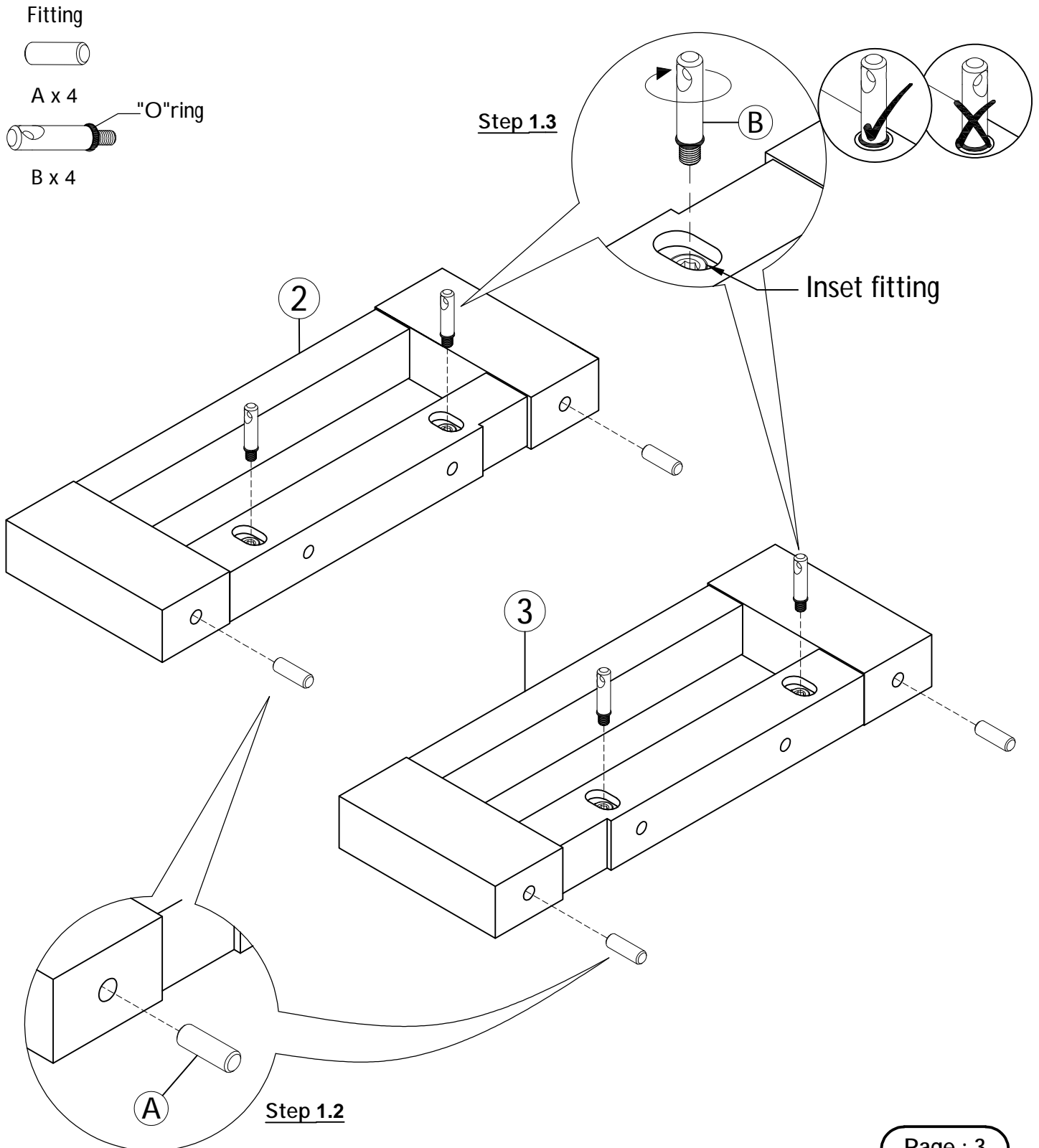

# Step By Step Assembly Instructions

## Step 2

- 2.1 : Attach leg frame left (2) & leg frame right (3) onto side aprons (4) as shown . Ensure steel dowels (B) are aligned correctly with the holes of mating parts before attaching.
- 2.2 : Secure parts (2) & (3) to parts (4) using 4x grub screws (C) as shown. Use an allen key (D) to turn fittings (C). Do not fully tighten grub screw.

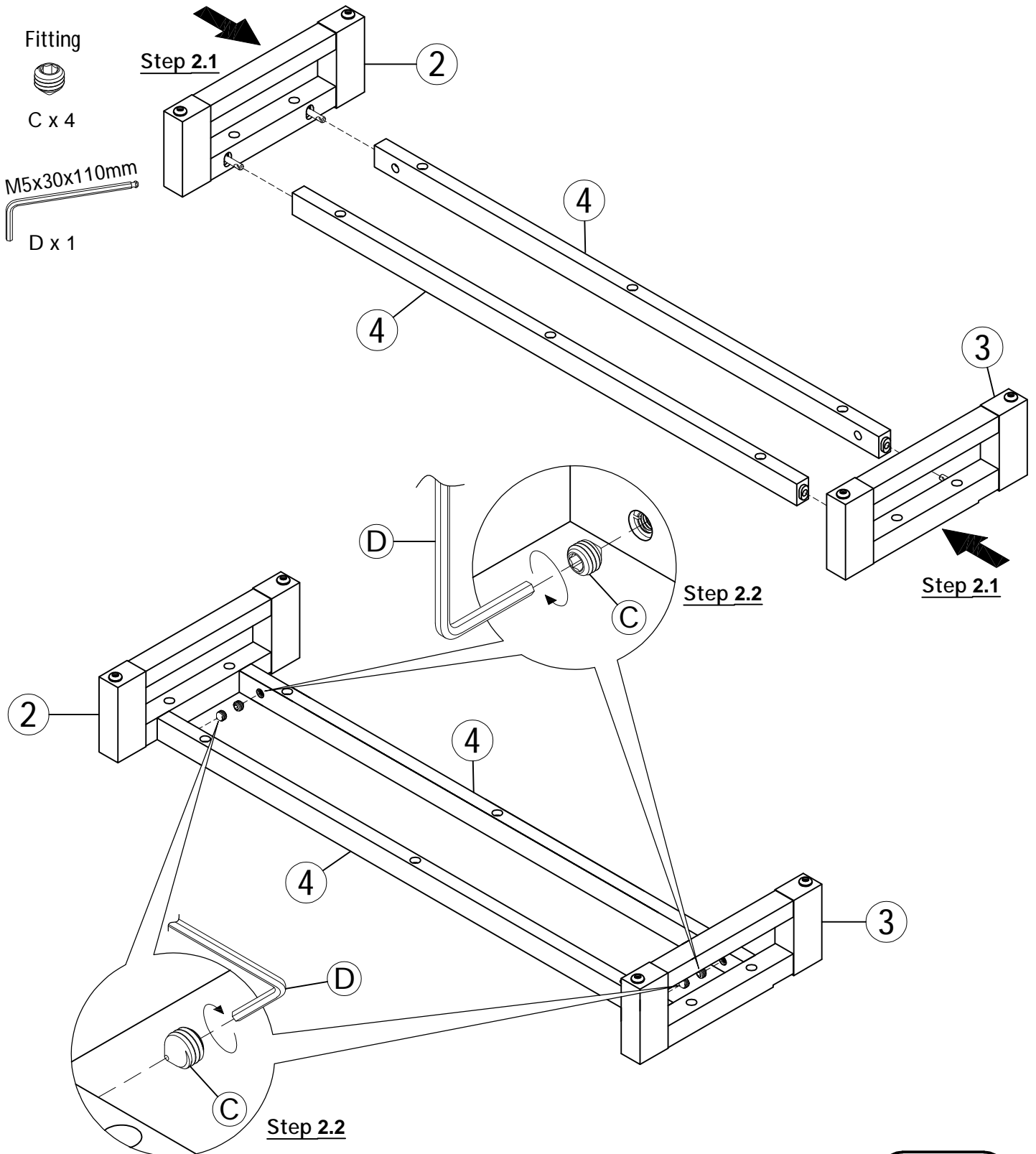

# Step By Step Assembly Instructions

- Step 3**
- 3.1 : Attach the structure assembled in step 2 onto top unit (1) as shown. Ensure wooden dowels (A) and the pre-drilled holes on side aprons (4) are aligned correctly to the holes on top unit (1) before attaching.
  - 3.2 : Secure the structure assembled in step 2 onto top unit (1) using 10x hex head bolts (F) as shown. Use an allen key (E) to turn fittings (F) clockwise to fix.
  - 3.3 : Using allen key (D) to re-tightening grub screw (C).
  - 3.4 : Stand the unit upright.

Fitting

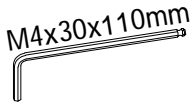

E x 1

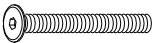

F x 10

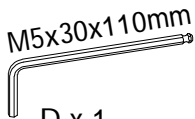

D x 1

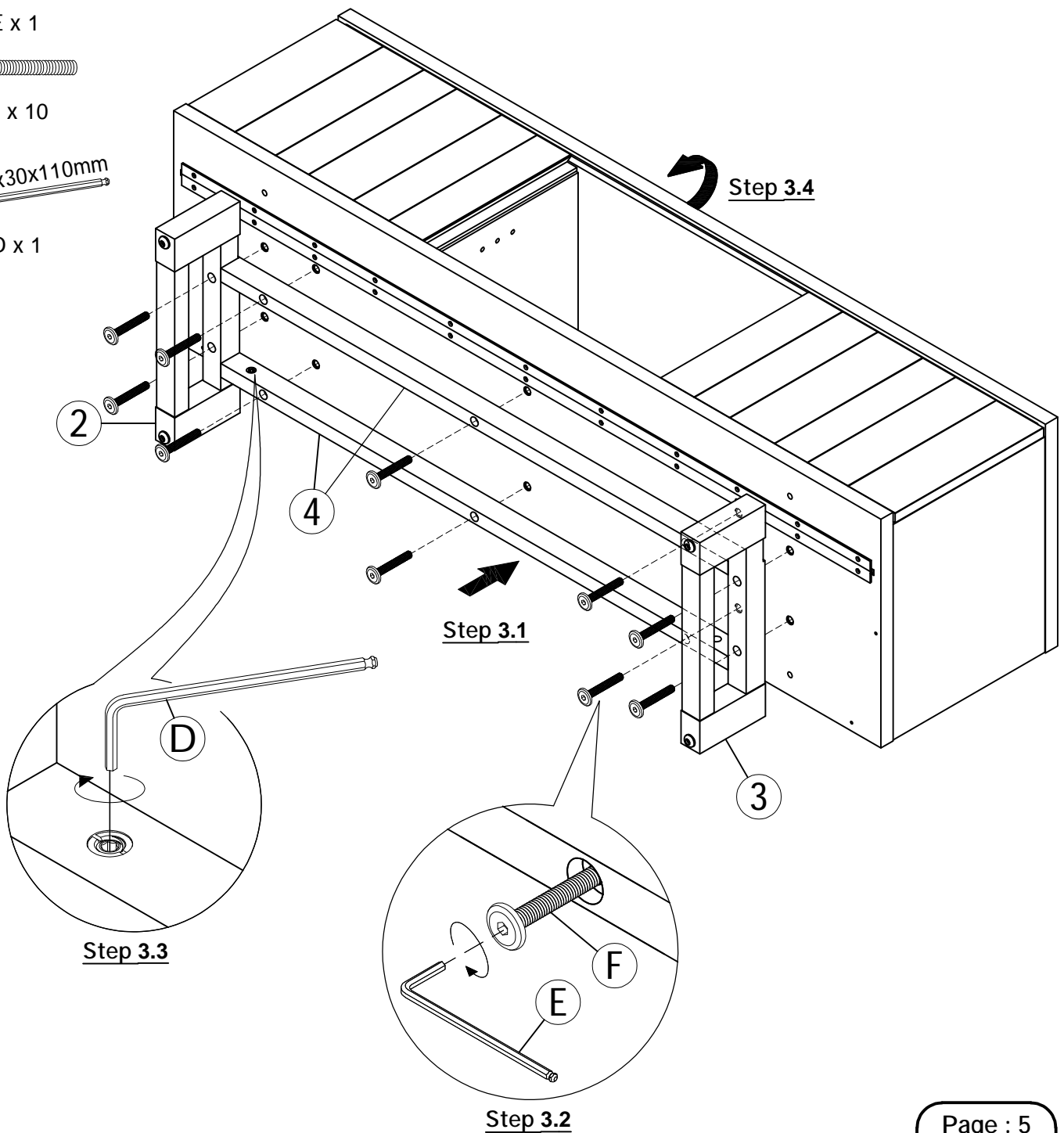

# Step By Step Assembly Instructions

- Step 4**
- 4.1 : Screw 4x shelf pins (G) into the inset fittings in partition of the unit (1) as shown.
  - 4.2 : Slide adjustable shelf B (6) into the unit. Ensure the notches on adjustable shelf B (6) are facing down.
  - 4.3 : Lower adjustable shelf B (6) onto the pins of shelf pins (G) as shown.
  - 4.4 : Push the left door to the right.

Fitting



G x 4

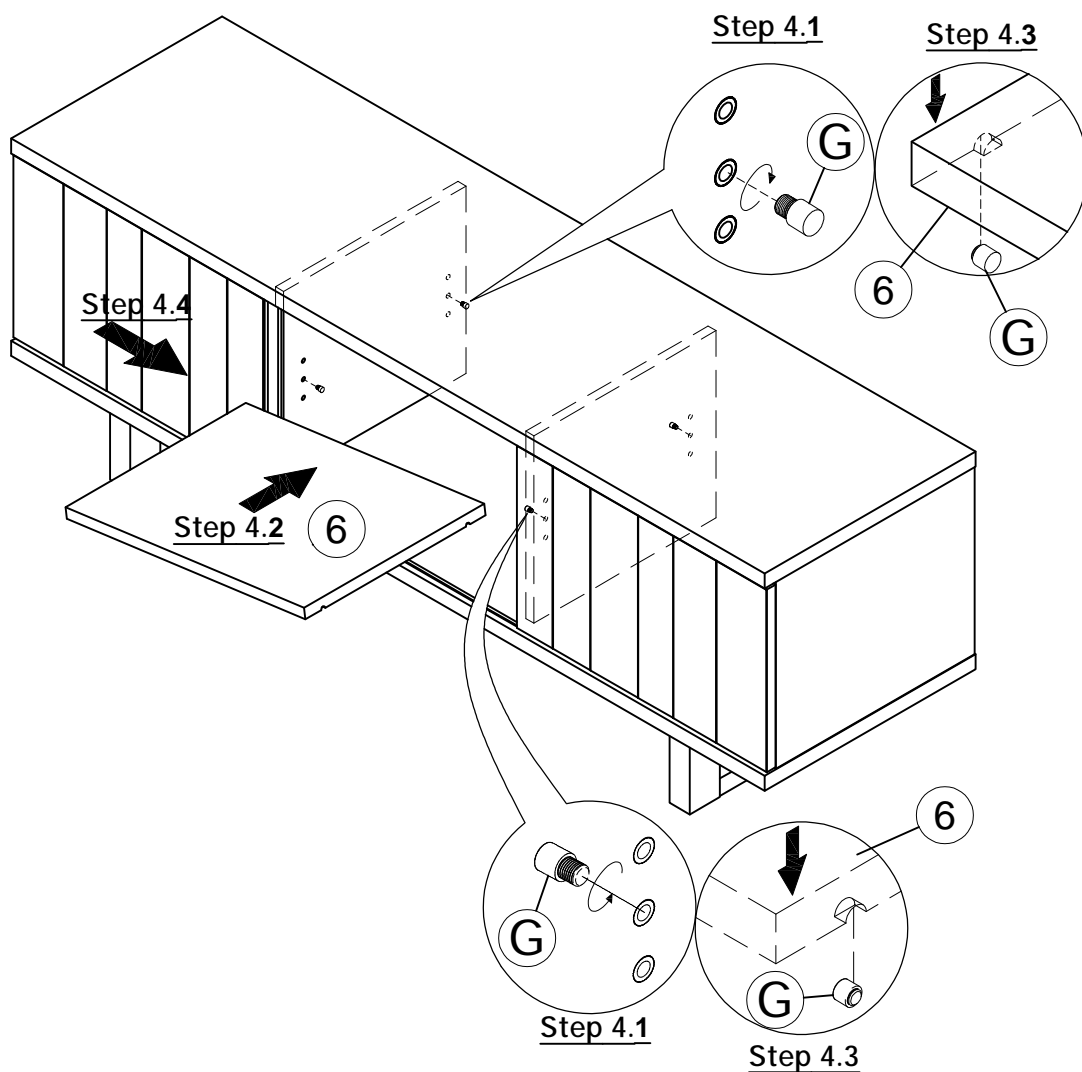

# Step By Step Assembly Instructions

- Step 5**
- 5.1 : Screw 2x shelf pins (G) into the inset fittings in partition of the unit (1) as shown.
  - 5.2 : Tilt adjustable shelf A (5) to a suitable angle as shown in the picture so as to slide them in.
  - 5.3 : Slide adjustable shelf A (5) into the unit. Ensure the notches on adjustable shelf A (5) is facing down, then lower the right side of adjustable shelf A (5) onto the pins of shelf pins (G) as shown.
  - 5.4 : Lift up left side of adjustable shelf A (5).
  - 5.5 : Screw 2x shelf pins (G) into the inset fittings on left panel of the unit as shown.
  - 5.6 : Lower adjustable shelf A (5) onto the pins of shelf pins (G) as shown.
  - 5.7 : Push the right door to the left.

Fitting



G x 4

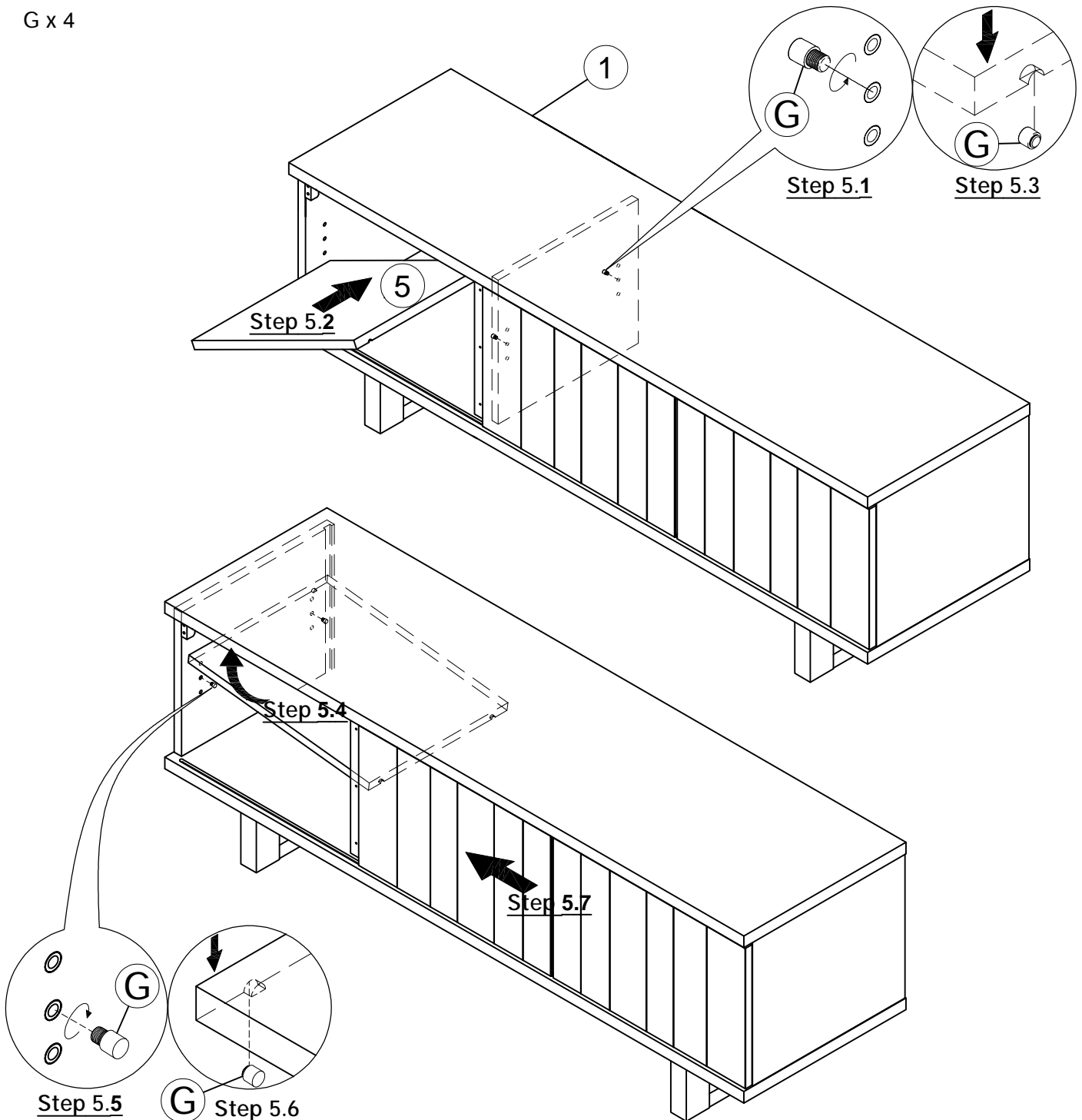

# Step By Step Assembly Instructions

- Step 6**
- 6.1 : Screw 2x shelf pins (G) into the inset fittings in partition of the unit (1) as shown.
  - 6.2 : Tilt adjustable shelf A (5) to a suitable angle as shown in the picture so as to slide them in.
  - 6.3 : Slide adjustable shelf A (5) into the unit. Ensure the notches on adjustable shelf A (5) is facing down, then lower the left side of adjustable shelf A (5) onto the pins of shelf pins (G) as shown.
  - 6.4 : Lift up right side of adjustable shelf A (5).
  - 6.5 : Screw 2x shelf pins (G) into the inset fittings on right panel of the unit as shown.
  - 6.6 : Lower adjustable shelf A (5) onto the pins of shelf pins (G) as shown.

Fitting



G x 4

