

WIDE SIDEBOARD

Stock number: 9199/9234-15

Thank you for purchasing this product. Please read the instructions carefully before use to ensure safe and satisfactory operation of this product.

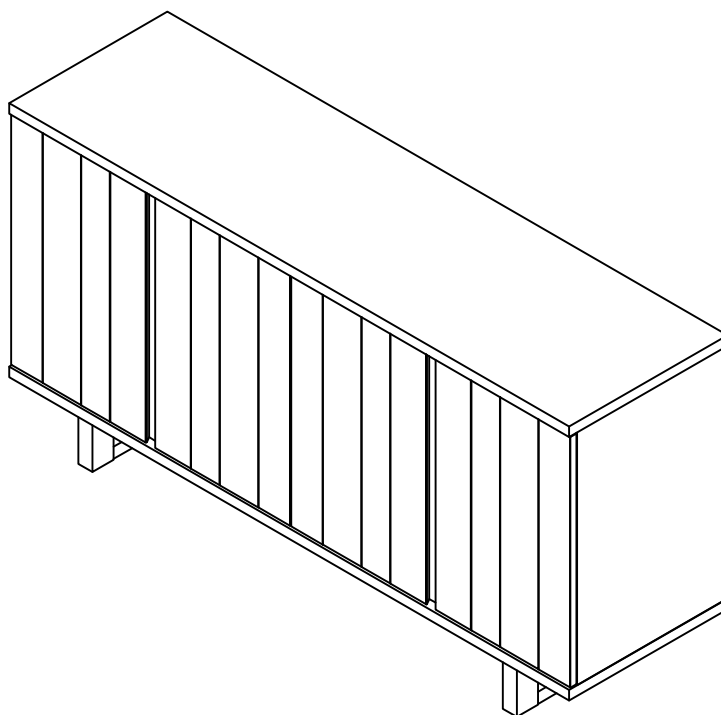

Pre-assembly preparation

Please ensure instructions are read in full before attempting to assemble this product.

Necessary Tools :

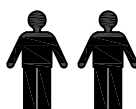

(Included)

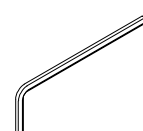

Please check the pack contents before attempting to assemble this product. A full checklist of components is given in this leaflet. If any components are missing, please contact the retailer from whom you bought this product.

This product takes approximately **30 MINUTES** to assemble with **2 PEOPLE**.

All assembly should be performed on a flat, stable, clean and soft surface.

This product is **HEAVY**, it should be assembled as near as possible to the point of use. **TAKE CARE WHEN LIFTING** to avoid personal injury and (or) damage to the product.

The fitting pack contains **SMALL ITEMS** which should be **KEPT AWAY FROM YOUNG CHILDREN**.

IMPORTANT: Retain these instructions for future reference.

Page : 1

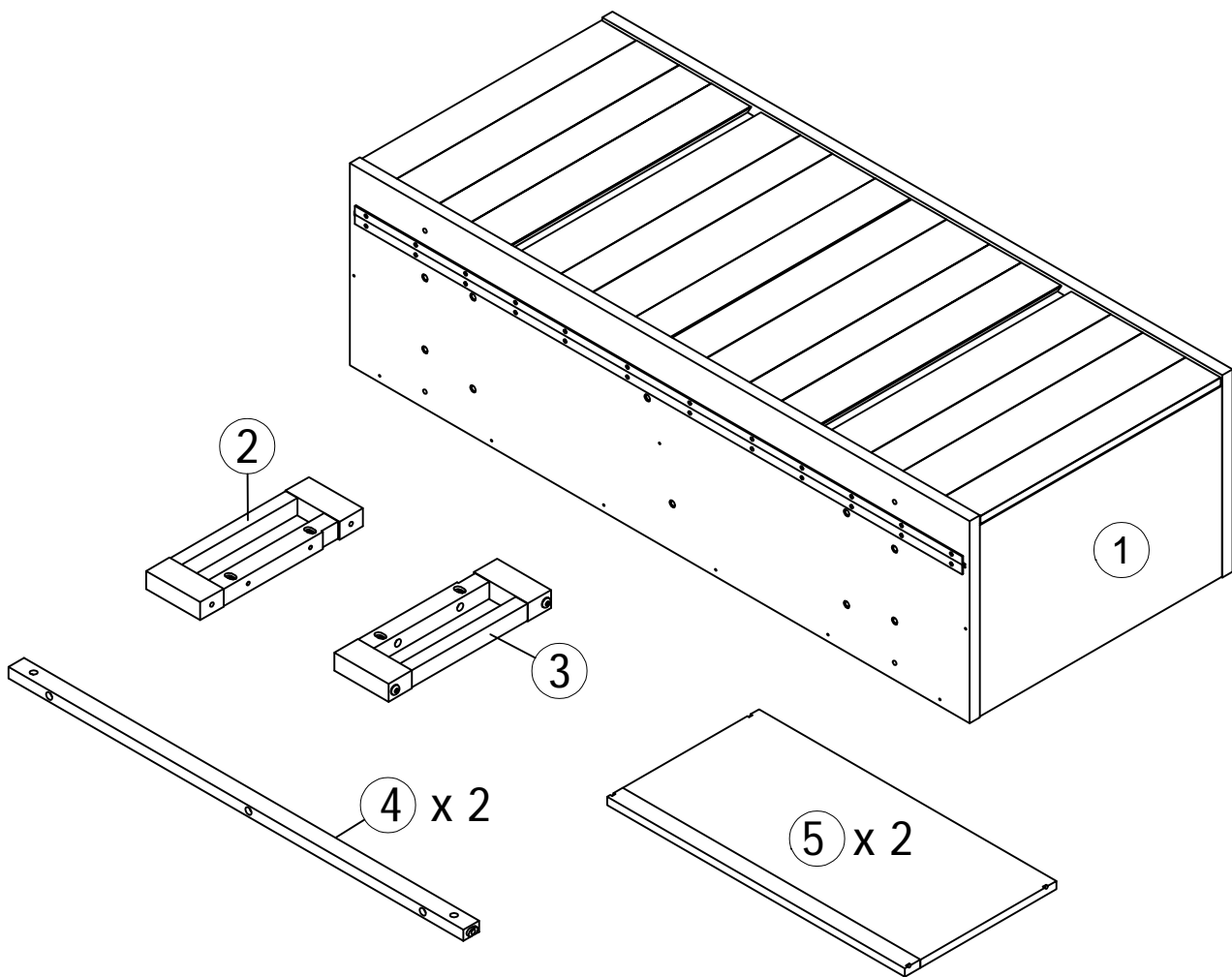

Fittings and parts checklist

Item	Description	Qty.	Item	Description	Qty.
1	Top unit	x 1	4	Side apron	x 2
2	Leg frame left	x 1	5	Adjustable shelf frame	x 2
3	Leg frame right	x 1			
A	Wooden dowel Ø10x30mm	x 4	E	Small allen key M4 x 30 x 110mm	x 1
B	Steel dowel Ø10 x 48.5mm	x 4	F	Head hex bolt M6 x 45mm	x 10
C	Grub screw M10 x 10mm	x 4	G	Shelf pin	x 8
D	Large allen key M5 x 30 x 110mm	x 1			

Step By Step Assembly Instructions

Step 1

- 1.1 : Lay all parts on a flat, stable, clean and soft surface.
- 1.2 : Insert 4x wooden dowels (A) into the pre-drilled holes on leg frame left (2) & leg frame right (3) as shown.
- 1.3 : Attach 4x steel dowels (B) into leg frame left (2) & leg frame right (3) by screwing fittings (B) into the inset fittings that are located on parts (2) & (3) as shown. Ensure the direction of the holes on fittings (B) are facing correctly as per diagram.

Fitting



A x 4

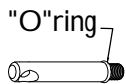

B x 4

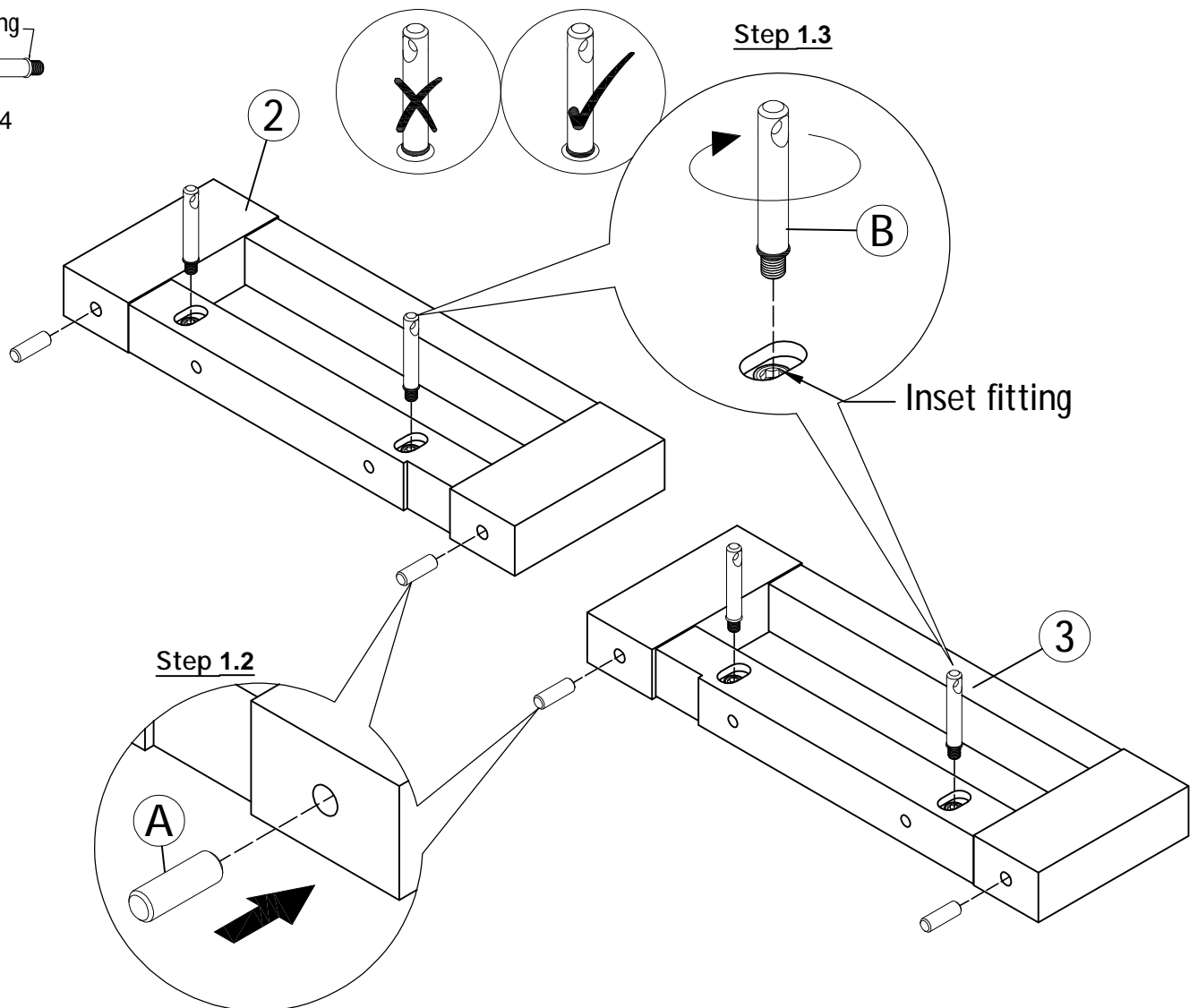

Step By Step Assembly Instructions

Step 2

- 2.1 : Attach leg frame left (2) & leg frame right (3) onto side aprons (4) as shown. Ensure steel dowels (B) are aligned correctly with the holes of mating parts before attaching.
- 2.2 : Secure parts (2) & (3) to parts (4) using 4x grub screws (C) as shown. Use an allen key (D) to turn fittings (C). Do not fully tighten grub screw.

Fitting



C x 4

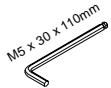

D x 1

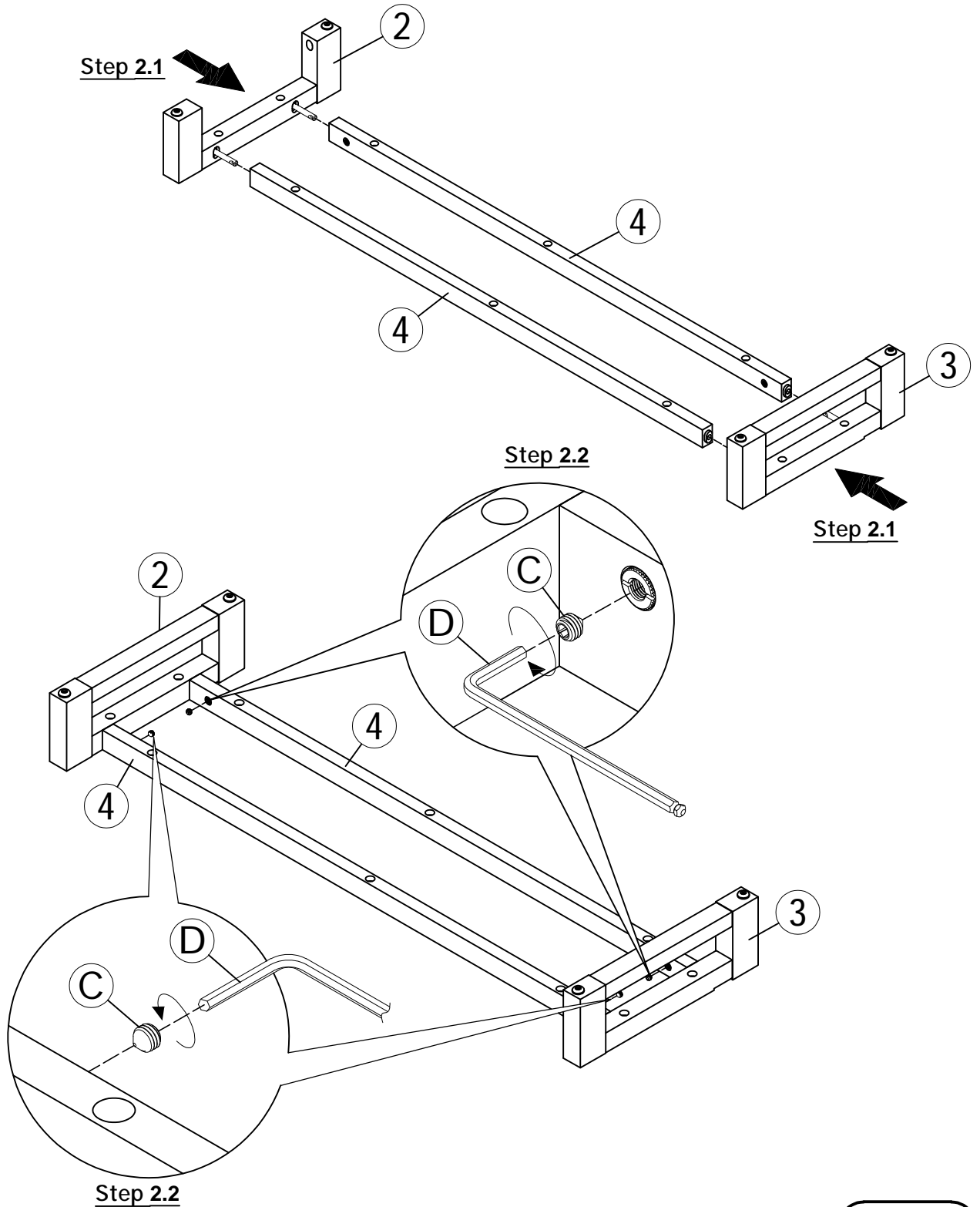

Step By Step Assembly Instructions

- Step 3**
- 3.1 : Attach the structure assembled in step 2 onto top unit (1) as shown. Ensure wooden dowels (A) and the pre-drilled holes on sides apron (4) are aligned correctly to the holes on top unit (1) before attaching.
 - 3.2 : Secure the structure assembled in step 2 onto top unit (1) using 10x hex head bolts (F) as shown. Use an allen key (E) to turn fittings (F) clockwise to fix.
 - 3.3 : Using allen key (D) to re-tightening grub screw (C).
 - 3.4 : Stand the unit upright.

Fitting



F x 10

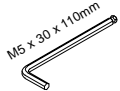

D x 1

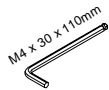

E x 1

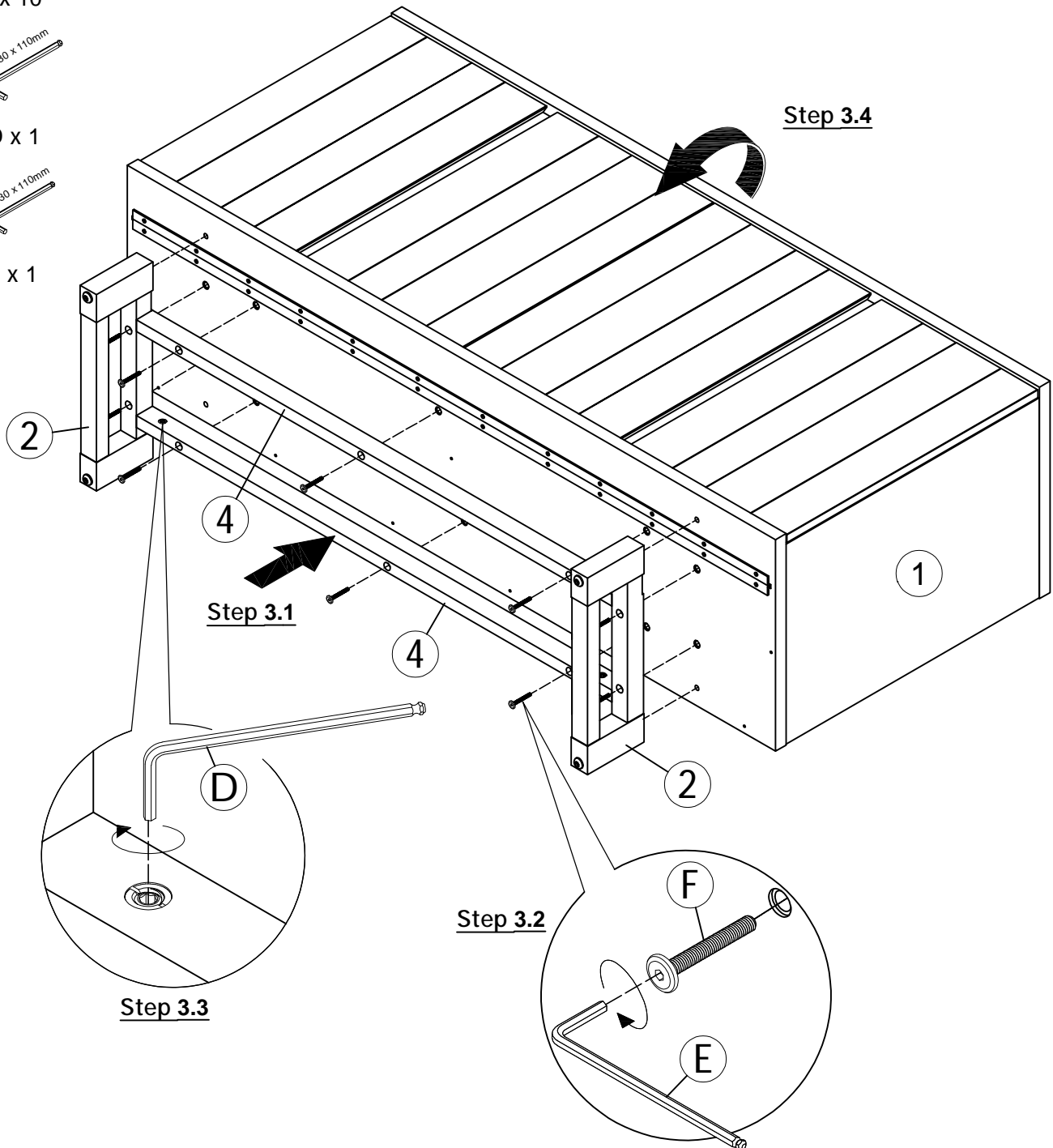

Step By Step Assembly Instructions

- Step 4**
- 4.1 : Screw 4x shelf pins (G) into the inset fittings in partition of the unit (1) as shown.
 - 4.2 : Tilt adjustable shelves (5) to a suitable angle as shown in the picture so as to slide them in.
 - 4.3 : Slide adjustable shelves (5) into the unit. Ensure the notches on adjustable shelves (5) are facing down, then lower the right & left sides of adjustable shelves (5) onto the pins of shelf pins (G) as shown.
 - 4.4 : Lift up left side and right side of adjustable shelves (5).
 - 4.5 : Screw 4x shelf pins (G) into the inset fittings on left and right panel of the unit as shown.
 - 4.6 : Lower adjustable shelves (5) onto the pins of shelf pins (G) as shown.

Fitting



G x 8

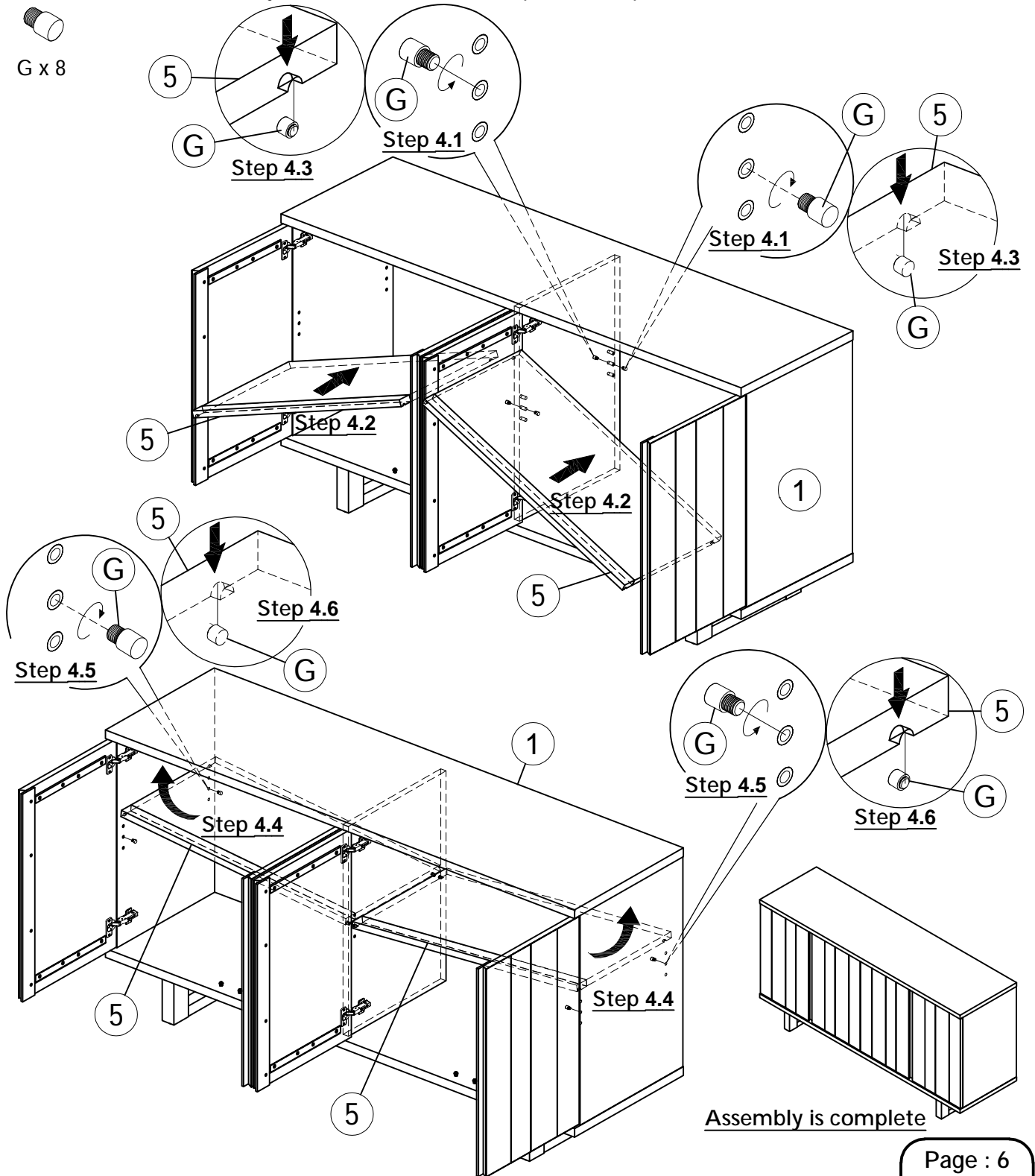

Hinge adjustment instructions

LATERAL ADJUSTMENT
by screw adjustment.

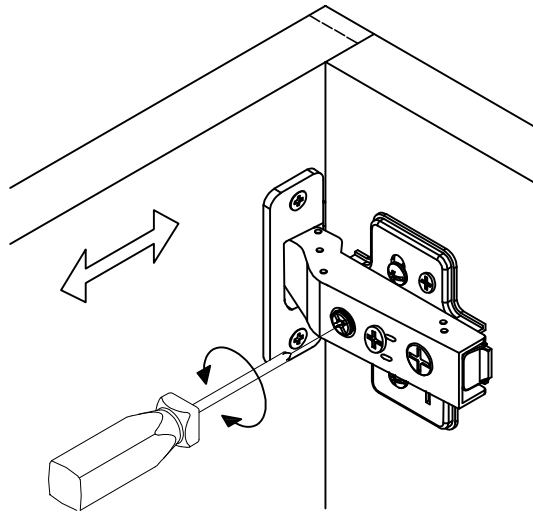

FRONT-TO-BACK
by slackening and retightening
the hinge-arm mounting screw.

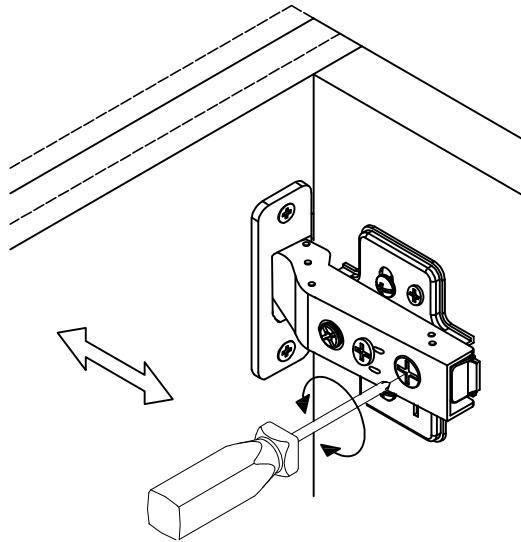

VERTICAL ADJUSTMENT
via slots on mounting plate by
slackening and retightening the
screws on mounting plate

1.1

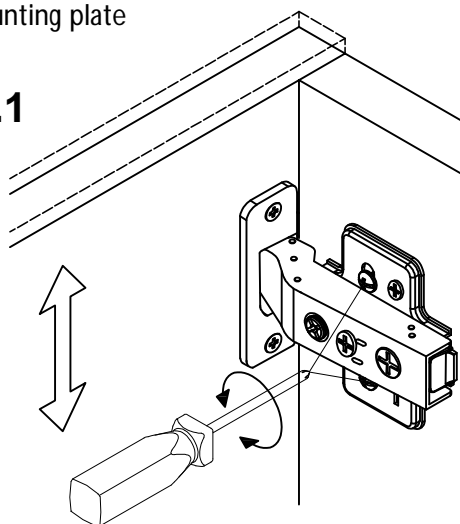

1.2

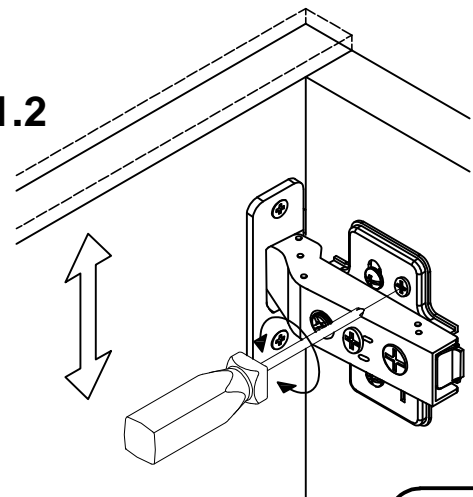

Hinge adjustment instructions

SLOW DOWN CLOSING
by screw adjustment to clockwise.

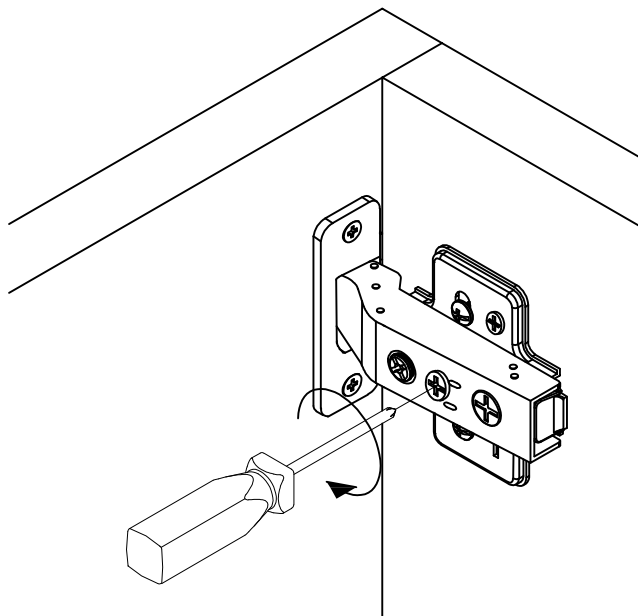

SPEED UP CLOSING
by screw adjustment to counter clockwise.

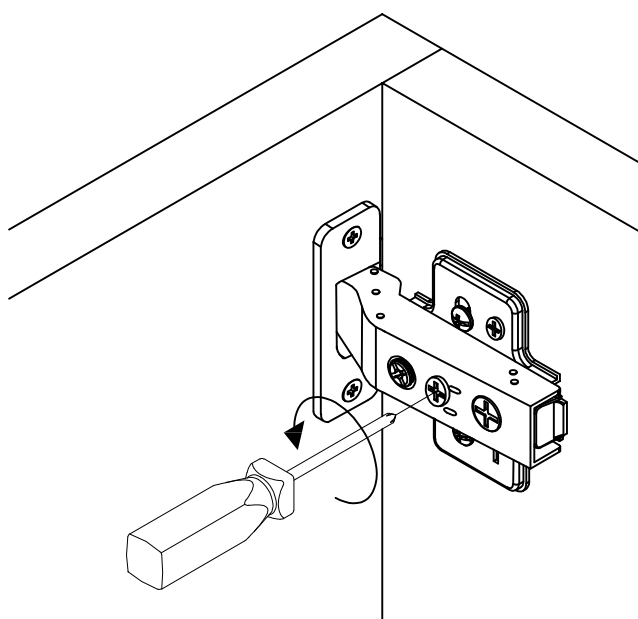

Hinge adjustment instructions

LATERAL ADJUSTMENT
by screw adjustment.

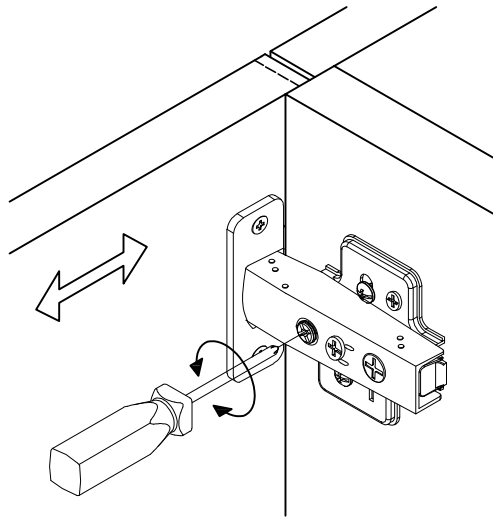

FRONT-TO-BACK
by slackening and retightening
the hinge-arm mounting screw.

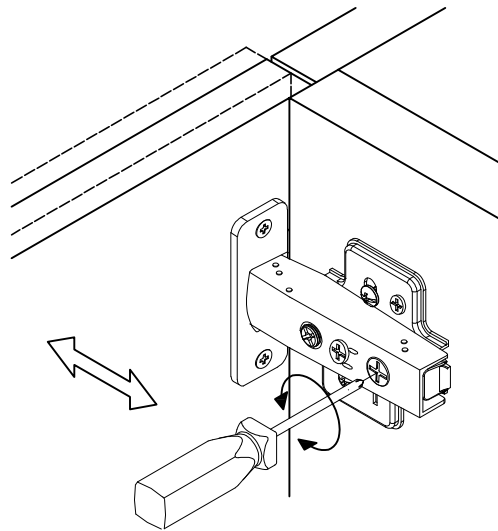

VERTICAL ADJUSTMENT
via slots on mounting plate by
slackening and retightening the
screws on mounting plate

1.1

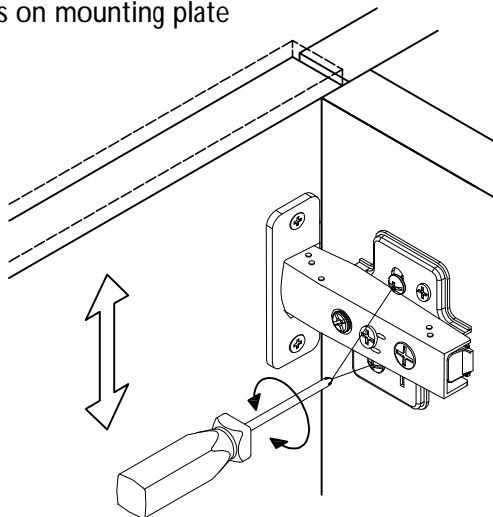

1.2

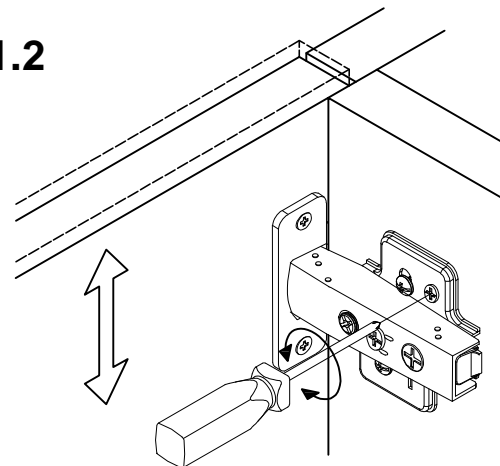

Hinge adjustment instructions

SLOW DOWN CLOSING

by screw adjustment to clockwise.

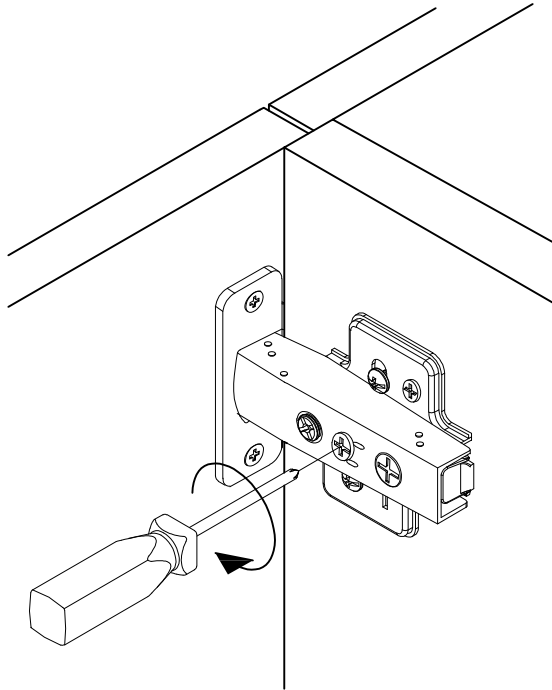

SPEED UP CLOSING

by screw adjustment to counter clockwise.

