

NARROW SIDEBOARD

Stock number: 9199-10

Thank you for purchasing this product. Please read the instructions carefully before use to ensure safe and satisfactory operation of this product.

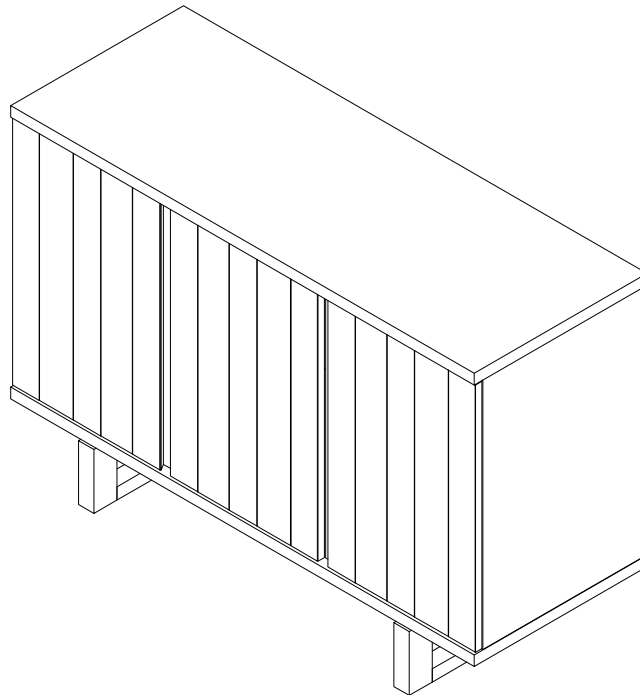

Pre-assembly preparation

Please ensure instructions are read in full before attempting to assemble this product.

Necessary Tools :

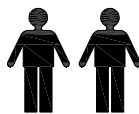

(Included)



Please check the pack contents before attempting to assemble this product. A full checklist of components is given in this leaflet. If any components are missing, please contact the retailer from whom you bought this product.

This product takes approximately **30 MINUTES** to assemble with **2 PEOPLE**.

All assembly should be performed on a flat, stable, clean and soft surface.





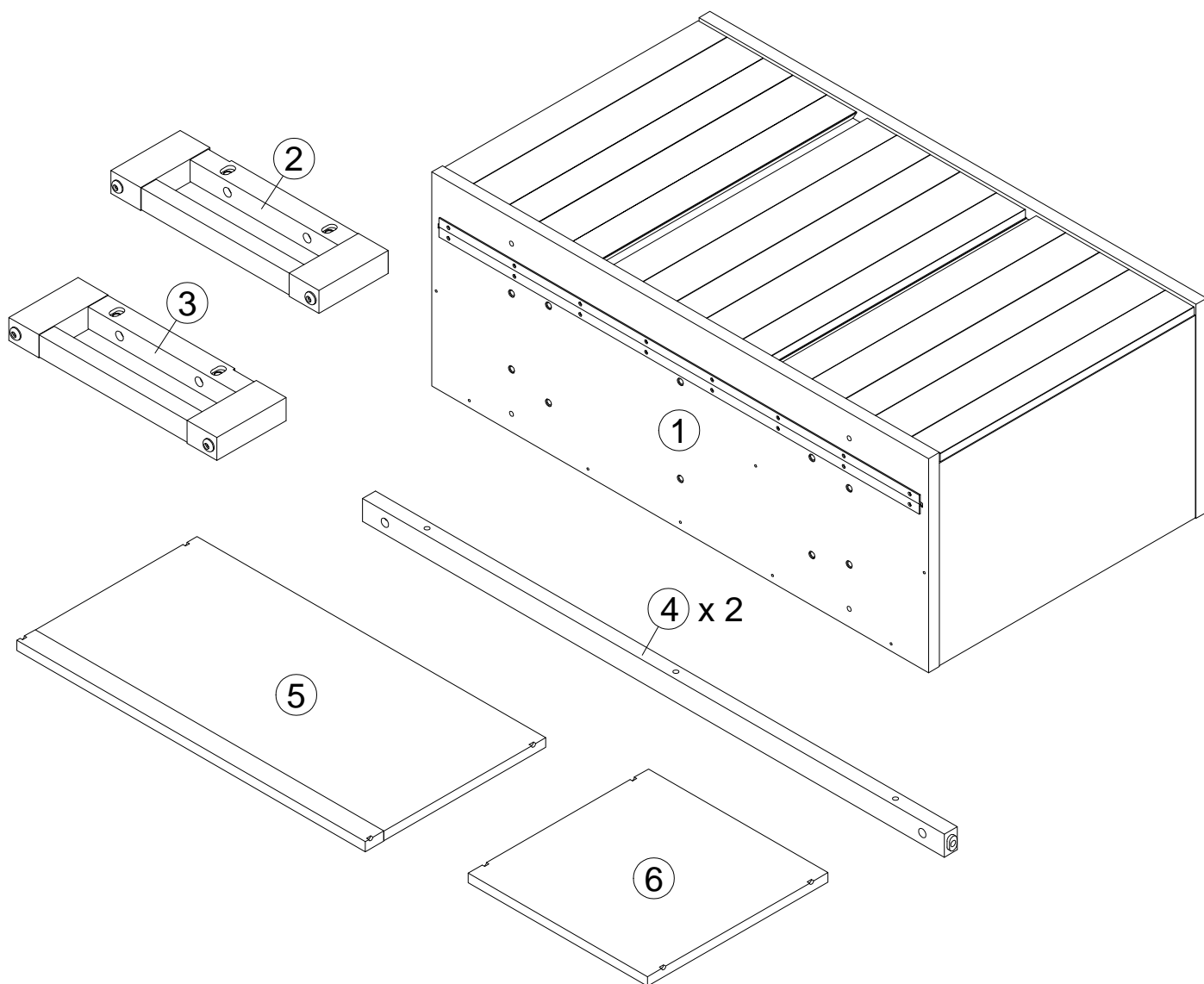

This product is **HEAVY**, it should be assembled as near as possible to the point of use. **TAKE CARE WHEN LIFTING** to avoid personal injury and (or) damage to the product

The fitting pack contains **SMALL ITEMS** which should be **KEPT AWAY FROM YOUNG CHILDREN**.

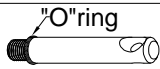
IMPORTANT: Retain these instructions for future reference.

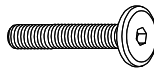

| Item | Description | Qty. | Item | Description | Qty. |
|------|-----------------|------|------|--------------------------|------|
| 1 | Top unit | x 1 | 4 | Side apron | x 2 |
| 2 | Leg frame left | x 1 | 5 | Adjustable shelf frame A | x 1 |
| 3 | Leg frame right | x 1 | 6 | Adjustable shelf B | x 1 |

| | | | | | | | |
|---|----------------------------|---|------|---|------------------------------------|---|-----|
| A | Steel dowel Ø10 x 67mm |  | x 4 | E | Shelf pin |  | x 8 |
| B | Wooden dowel Ø10 x 30mm |  | x 4 | F | Large allen key M5 x 30 x 110mm |  | x 1 |
| C | Grub screw M10 x 10mm |  | x 4 | G | Small allen key M4 x 30 x 110mm |  | x 1 |
| D | Hex head bolt M6 x 45mm |  | x 10 | | | | |

Step By Step Assembly Instructions

- Step 1**
- 1.1 : Lay all parts on a flat, stable, clean and soft surface.
 - 1.2 : Insert 4x steel dowels (A) into legs frame (2) & (3) by screwing fittings (A) into the inset fittings that are located on part (2) & (3) as shown. Ensure the direction of the holes on fittings (B) are facing the correct direction as per diagram.
 - 1.3 : Insert 4x wooden dowels (B) into the pre-drilled holes on parts legs frame (2) & (3) as shown.
 - 1.4 : Attach legs frame (2) & (3) onto side aprons (4) as shown. Ensure steel dowels (A) are aligned correctly with the holes of mating parts before attaching.
 - 1.5 : Secure parts (2) & (3) to parts (4) using 4x grub screws (C) as shown. Use an large allen key (F) to turn fittings (C). **Do not fully tighten grub screw.**

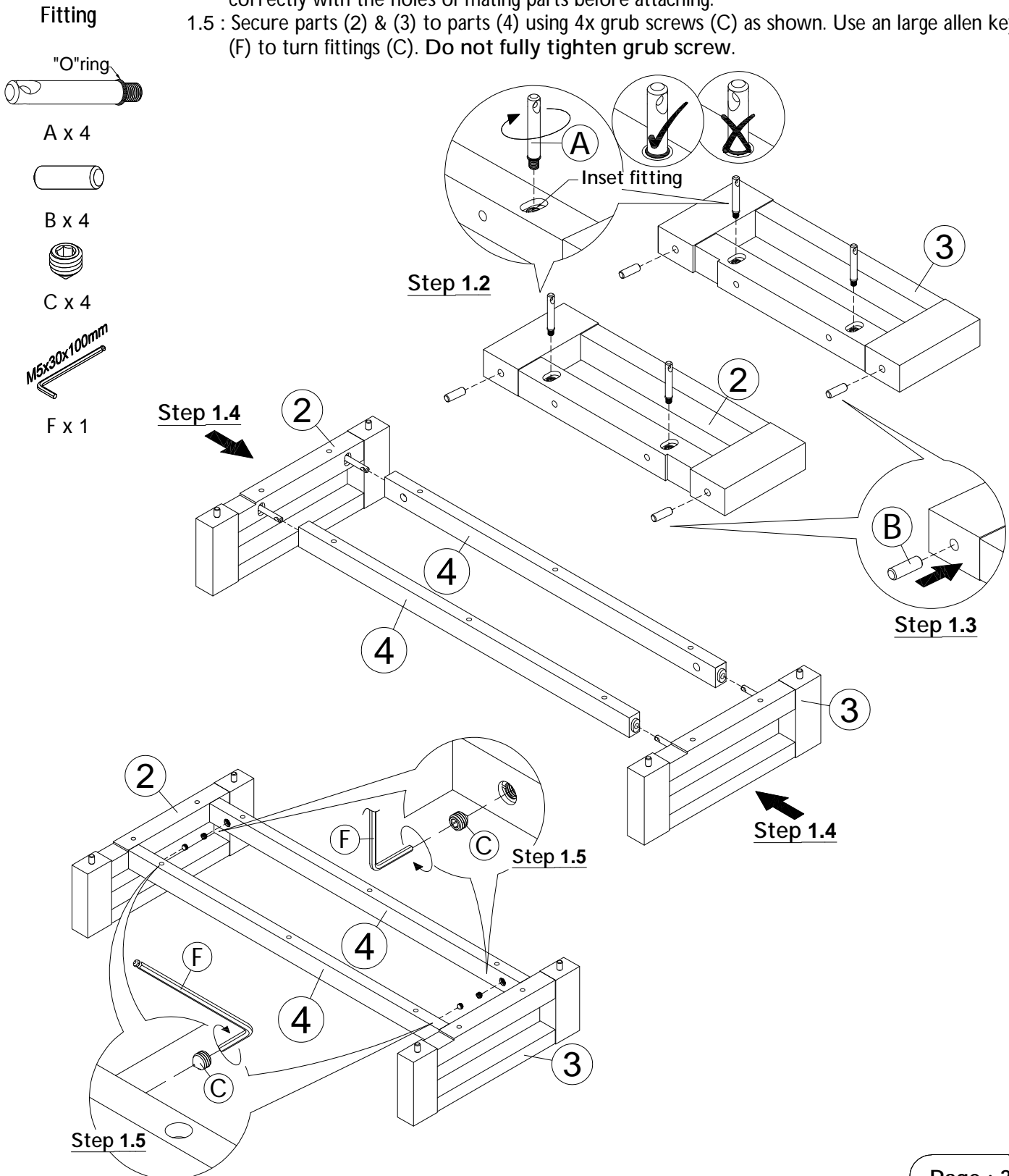

Step By Step Assembly Instructions

- Step 2**
- 2.1 : Attach the structure assembled in step 1 onto top unit (1) as shown. Ensure wooden dowels (B) and the pre-drilled holes on side aprons (4) are aligned correctly to the holes on top unit (1) before attaching.
- 2.2 : Secure the structure assembled in step 1 onto top unit (1) using 10x hex head bolts (D) as shown. Use a small allen key (G) to turn fittings (D) clockwise to fix.
- 2.3 : Using large allen key (F) to re-tightening grub screw (C).
- 2.4 : Stand the unit upright.

Fitting

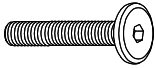

D x 10



G x 1



F x 1

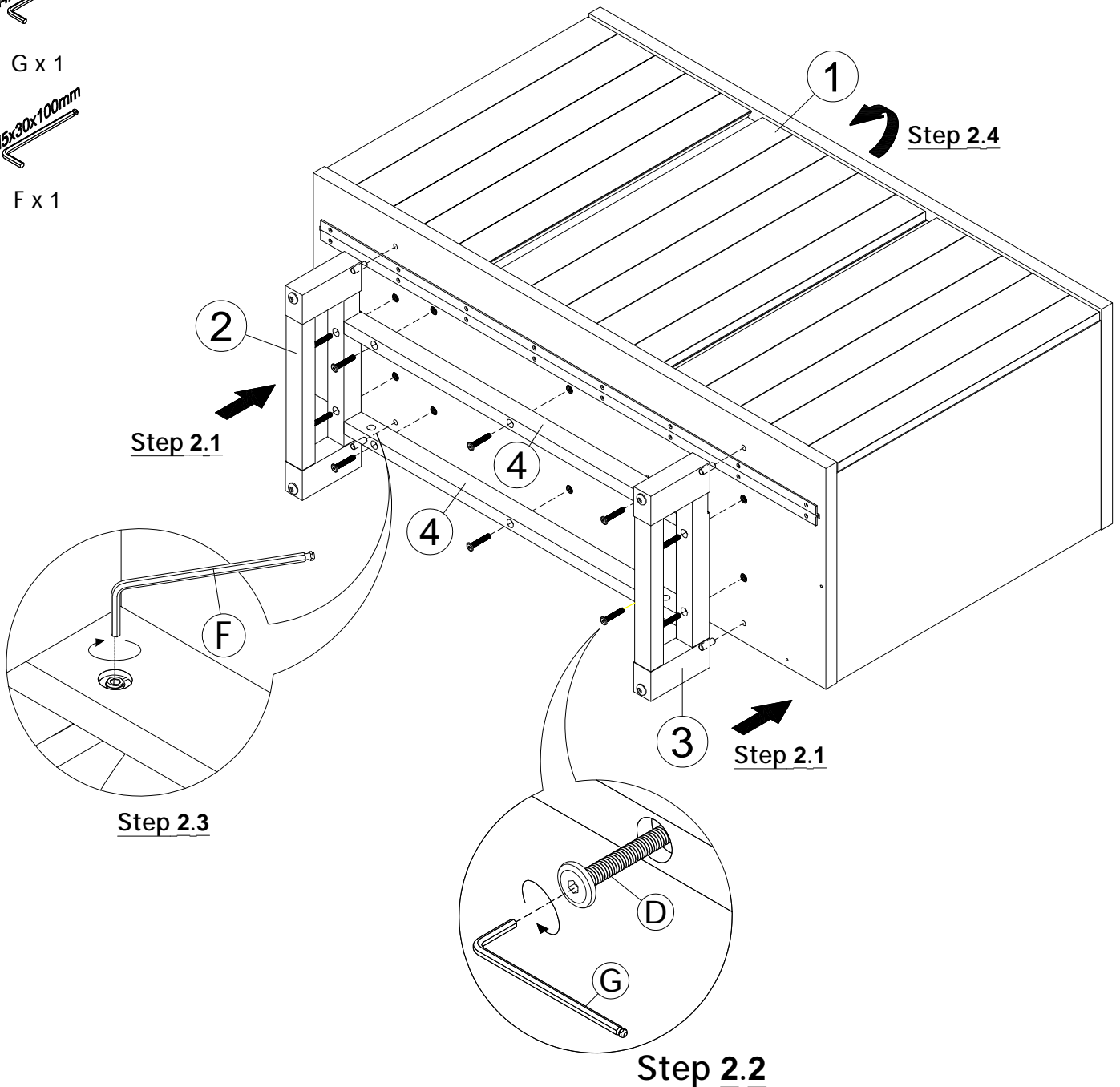

Step By Step Assembly Instructions

Step

3

- 3.1 : Screw 4x shelf pins (E) into the inset fittings in right side panel & partition of the unit (1) as shown.
- 3.2 : Tilt adjustable shelves (5) & (6) to a suitable angle as shown in the picture so as to slide them in.
- 3.3 : Slide adjustable shelves (5) & (6) into the unit. Ensure the notches on adjustable shelves (5) & (6) are facing down, then lower the right sides of adjustable shelves (5) & (6) onto the pins of shelf pins (E) as shown.
- 3.4 : Lift up left sides of adjustable shelves (5) & (6).
- 3.5 : Screw 4x shelf pins (E) into the inset fittings on left side panel & partition of the unit (1) as shown.
- 3.6 : Lower adjustable shelves (5) & (6) onto the pins of shelf pins (E) as shown.

Fitting



E x 8

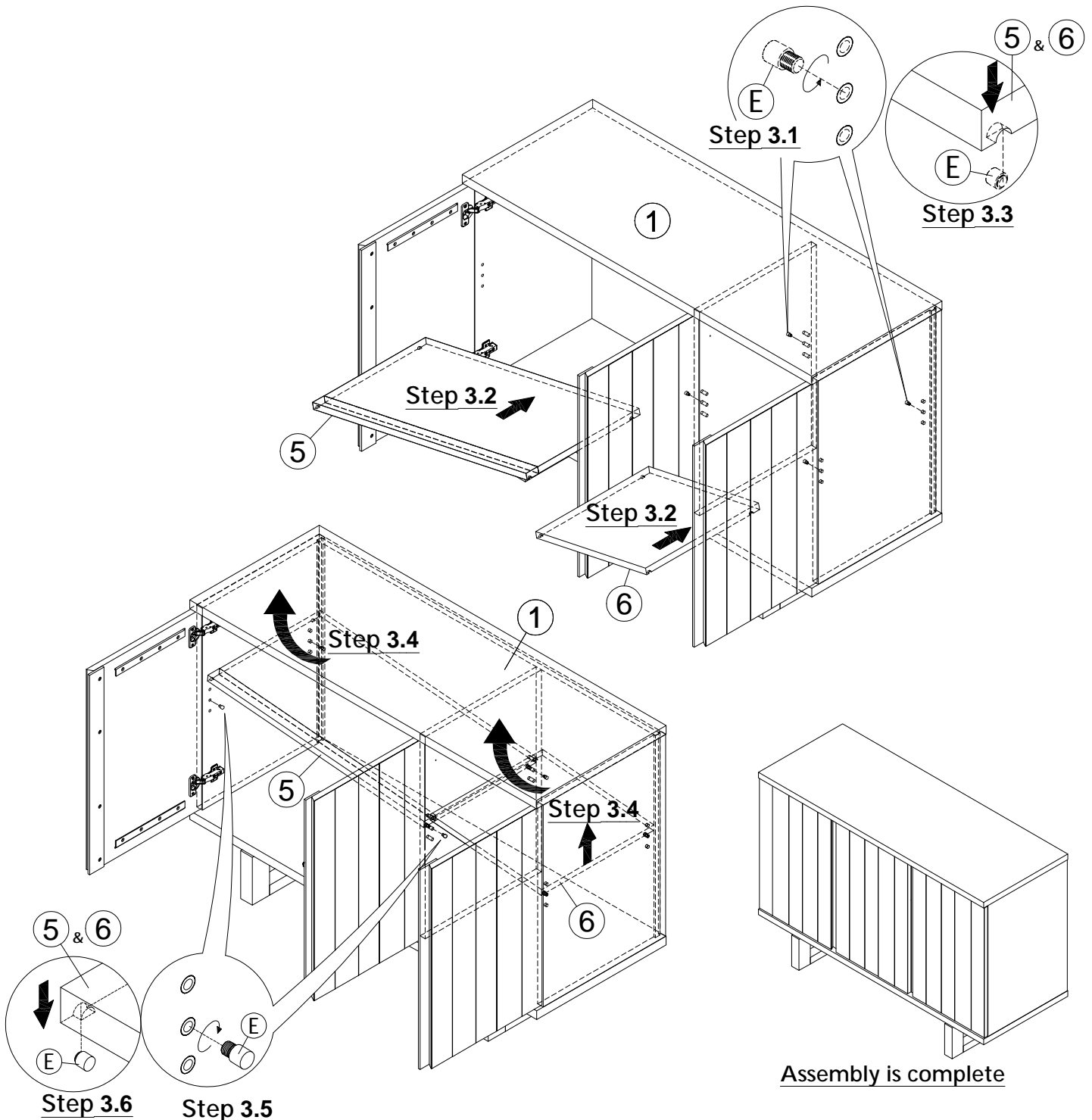

Hinge adjustment instructions

LATERAL ADJUSTMENT
by screw adjustment.

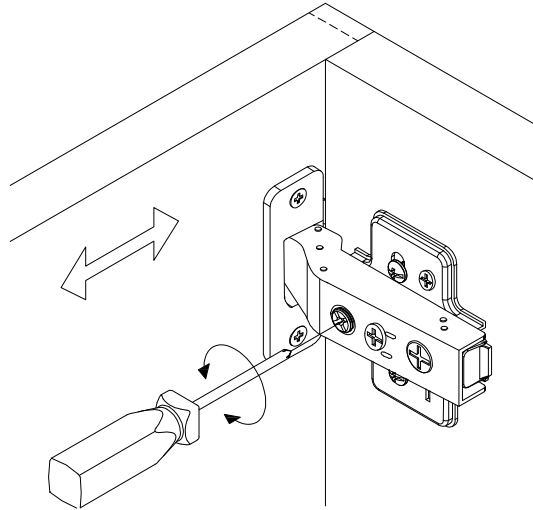

FRONT-TO-BACK
by slackening and retightening
the hinge-arm mounting screw.

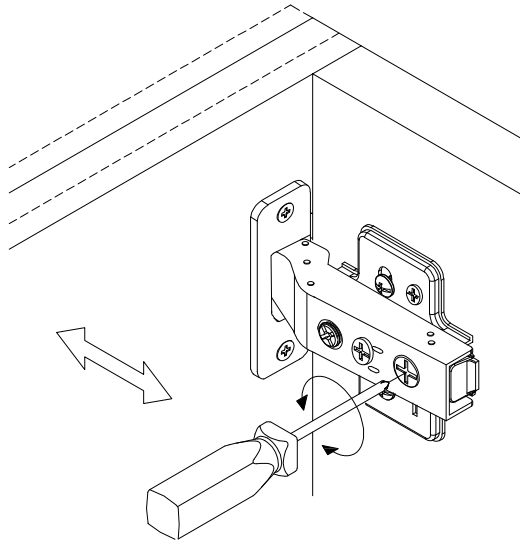

VERTICAL ADJUSTMENT
via slots on mounting plate by
slackening and retightening the
screws on mounting plate

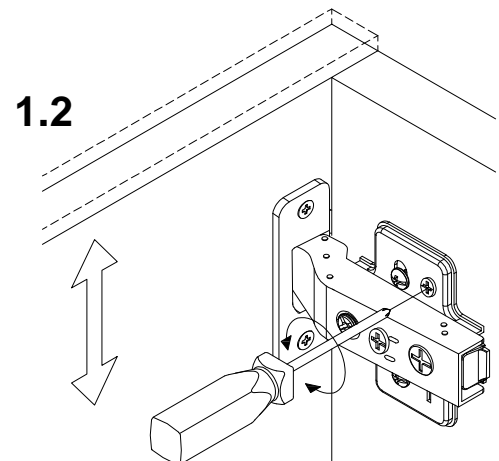
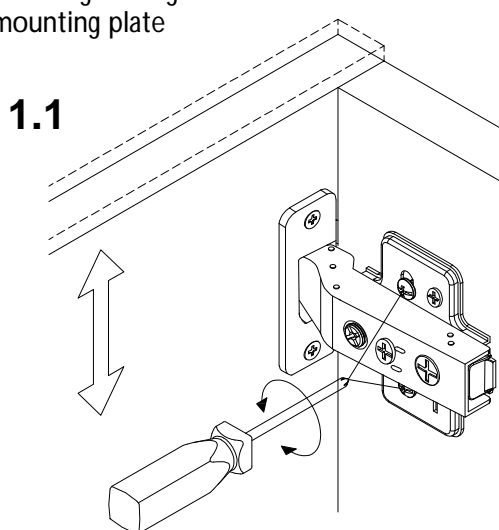

Hinge adjustment instructions

SLOW DOWN CLOSING

by screw adjustment to clockwise.

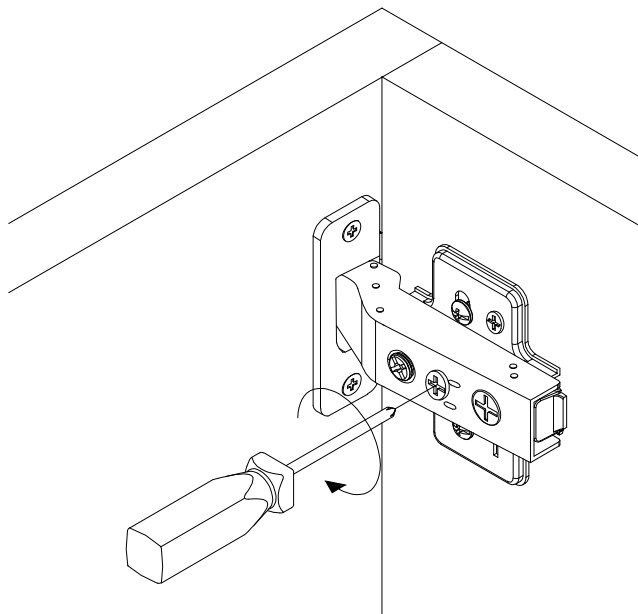

SPEED UP CLOSING

by screw adjustment to counter clockwise.

