

COFFEE TABLE

Stock number: 9199/9234-05

Thank you for purchasing this product. Please read the instructions carefully before use to ensure safe and satisfactory operation of this product.

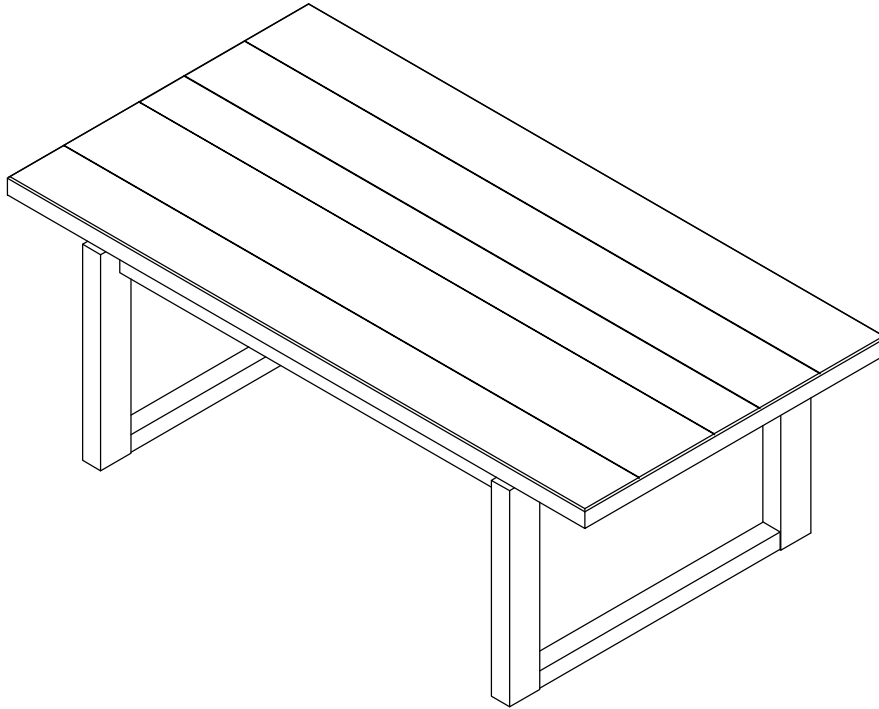

Pre-assembly preparation

Please ensure instructions are read in full before attempting to assemble this product.

Necessary Tools : Pozi screwdriver

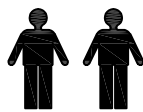

Pz 2 or Pz 3

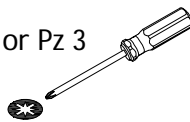

(Included)

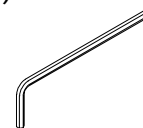

Please check the pack contents before attempting to assemble this product. A full checklist of components is given in this leaflet. If any components are missing, please contact the retailer from whom you bought this product.

This product takes approximately **15 MINUTES** to assemble with **2 PEOPLE**.

All assembly should be performed on a flat, stable, clean and soft surface.



This product is **HEAVY**, it should be assembled as near as possible to the point of use. **TAKE CARE WHEN LIFTING** to avoid personal injury and (or) damage to the product

The fitting pack contains **SMALL ITEMS** which should be **KEPT AWAY FROM YOUNG CHILDREN**.

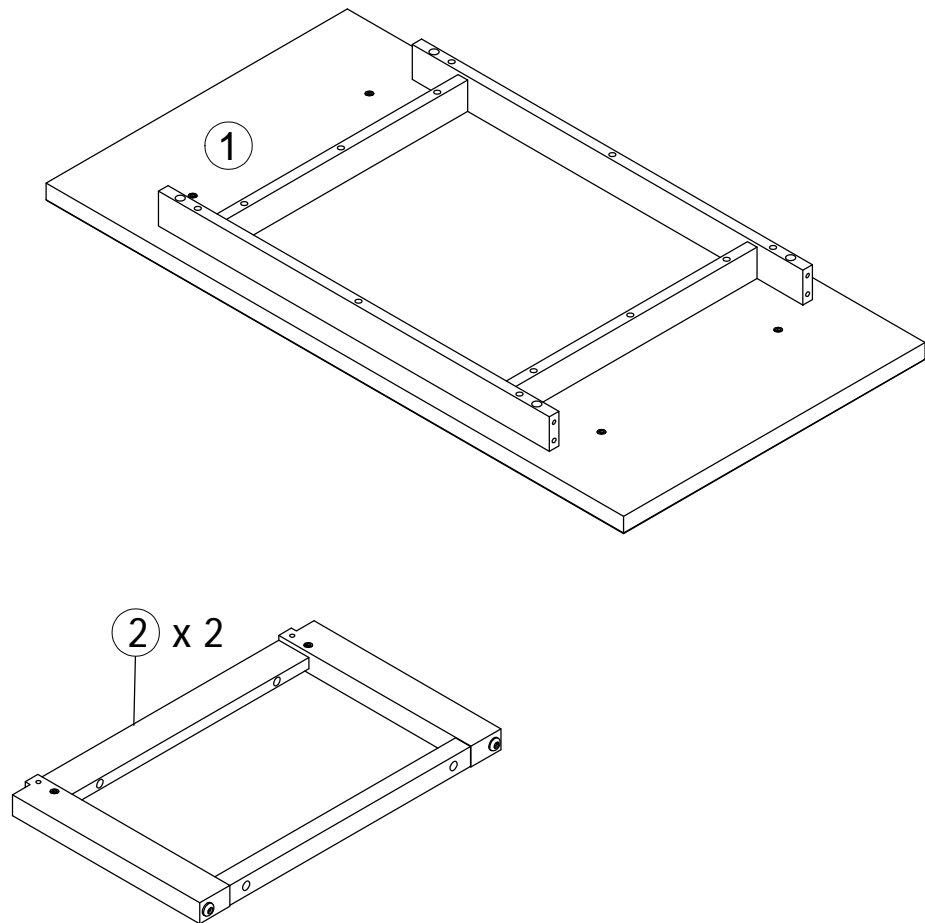
IMPORTANT: Retain these instructions for future reference.

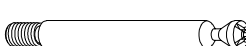
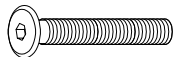
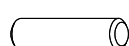

Fittings and parts checklist

Item	Description	Qty.	Item	Description	Qty.
1	Table top	x 1	2	Leg frame	x 2
A	Steel dowel Ø7 x 52mm 	x 4	D	Hex head bolt M6 x 60mm 	x 4
B	Wooden dowel Ø8 x 40mm 	x 4	E	Allen key M4 x 30 x 110mm 	x 1
C	Grub screw M8 x 8mm 	x 4			

Step By Step Assembly Instructions

Step 1

1.1 : Lay all parts on a flat, stable, clean and soft surface.

1.2 : Attach 4x steel dowels (A) into leg frames (2) by screwing fittings (A) into the inset fittings that are located on parts (2) as shown. Use a pozi screwdriver to turn fittings (A) clockwise to fix.

1.3 : Insert 4x wooden dowels (B) into the pre-drilled holes on legs frame (2) as shown.

Fitting

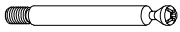

A x 4

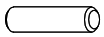

B x 4

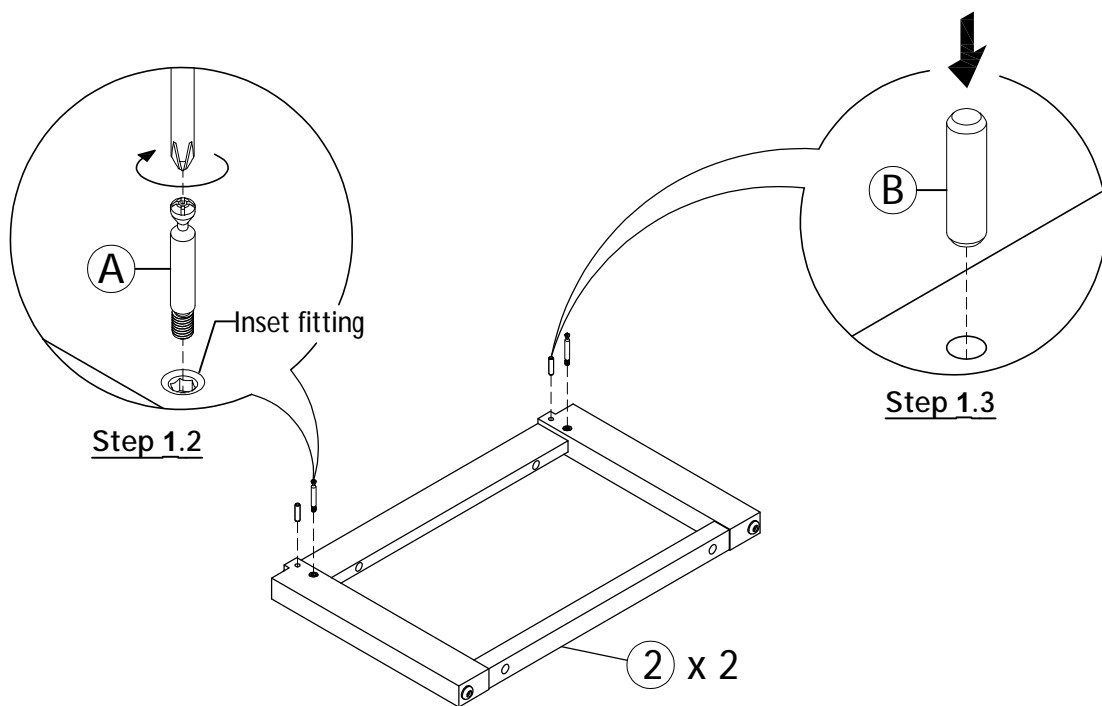

Step By Step Assembly Instructions

Step 2

- 2.1 : Attach legs frame (2) onto table top (1) as shown. Ensure steel dowels (A) and wooden dowels (B) on legs frame (2) are aligned correctly with the pre-drilled holes on table top (1) before attaching.
- 2.2 : Secure legs frame (2) to table top (1) by using 4x grub screws (C) as shown. Use allen key (E) to turn fittings (C) clockwise to fix.
- 2.3 : Secure legs frame (2) to table top (1) by using 4x hex head bolts (D) as shown. Use allen key (E) to turn bolts clockwise to fix.
- 2.4 : Stand the table upright.

Fitting



C x 4

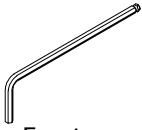

E x 1

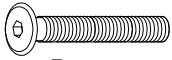

D x 4

