

TRIPLE WARDROBE

Stock number: 9172-83

Thank you for purchasing this product. Please read the instructions carefully before use to ensure safe and satisfactory operation of this product.

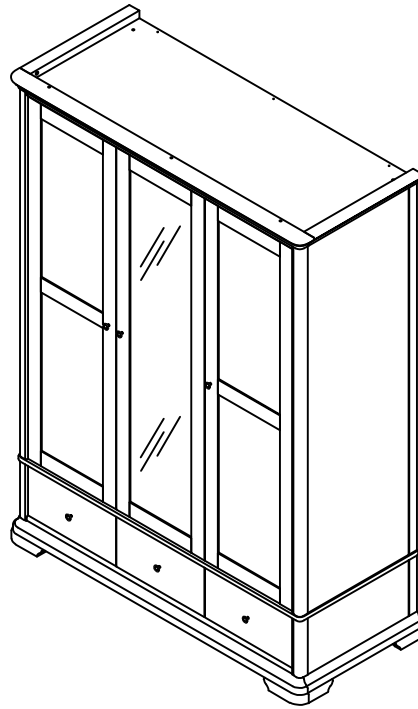

Pre-assembly preparation

Please ensure instructions are read in full before attempting to assemble this product.

Necessary Tools : Pozi screwdriver and Phillips screwdriver

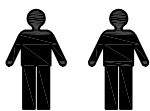

Pz 2 or Pz 3

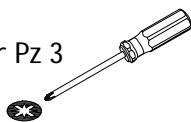

Ph 2



(Included)

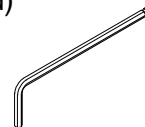

Please check the pack contents before attempting to assemble this product. A full checklist of components is given in this leaflet. If any components are missing, please contact the retailer from whom you bought this product.

This product takes approximately **30-40 MINUTES** to assemble with **2 PEOPLE**.

All assembly should be performed on a flat, stable, clean and soft surface.







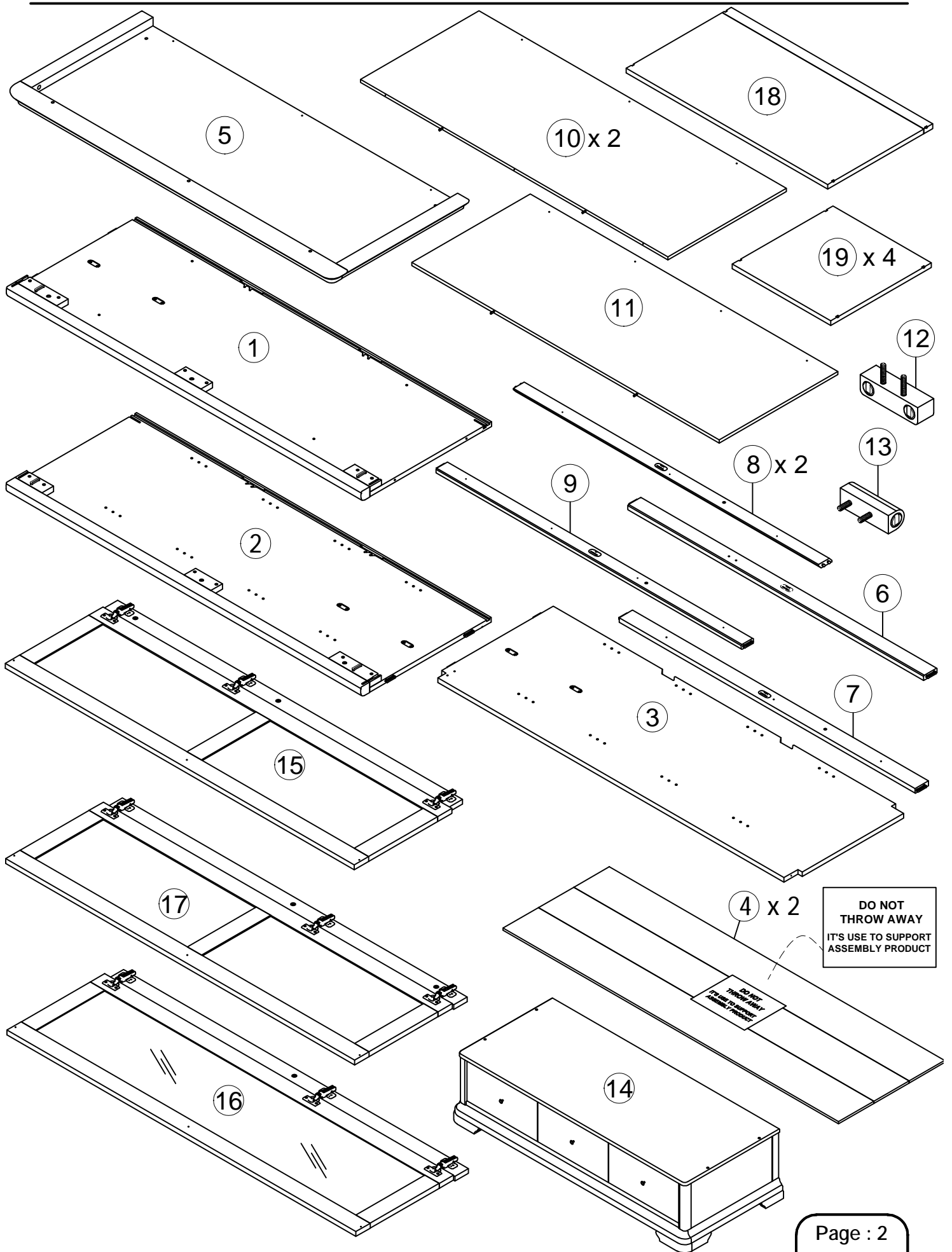



This product is **HEAVY**, it should be assembled as near as possible to the point of use. **TAKE CARE WHEN LIFTING** to avoid personal injury and (or) damage to the product

The fitting pack contains **SMALL ITEMS** which should be **KEPT AWAY FROM YOUNG CHILDREN**.

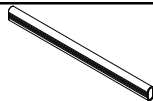
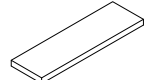
IMPORTANT: Retain these instructions for future reference.



Fittings and parts checklist

Item	Description	Qty.		Item	Description	Qty.	
1	Side frame left	x 1		10	Back panel A	x 2	
2	Side frame right	x 1		11	Back panel B	x 1	
3	Partition	x 1		12	Door stopper	x 1	
4	Honeycomb used as support for Assembly	x 2		13	Support door stopper	x 1	
5	Top frame	x 1		14	Triple wardrobe base	x 1	
6	Top front rail	x 1		15	Door frame left	x 1	
7	Bottom front rail	x 1		16	Door frame center	x 1	
8	Middle back rail	x 2		17	Door frame right	x 1	
9	Bottom back rail	x 1		18	Removable shelf frame	x 1	
				19	Adjustable shelf	x 4	
A	Hanger rail support 20 x 14 x 50mm	x 8		G	Shelf pin	x 20	
B	Hi-Lo Screw Ø4 x 50mm	x 7		H	Clothes rail bar	x 1	
C	Round head screw Ø4 x 25mm	x 19		J	Clothes rail bar	x 1	
D	Felt 3 x 20 x 60mm	x 4		K	Round head bolt Ø4 x 28mm	x 3	
E	Hex head bolt M6 x 25mm	x 5		L	Handle	x 3	
F	Allen key M4 x 30 x 110mm	x 1		M	Plastic Leveler	x 2	

Step by step assembly instructions

- Step 1** 1.1 : Lay all parts onto a flat, stable, clean and soft surface.
1.2 : Push 8x hanger rail supports (A) onto the pre-drilled holes on side frames (1) & (2) and partition (3) as shown.

Fitting



A x 8

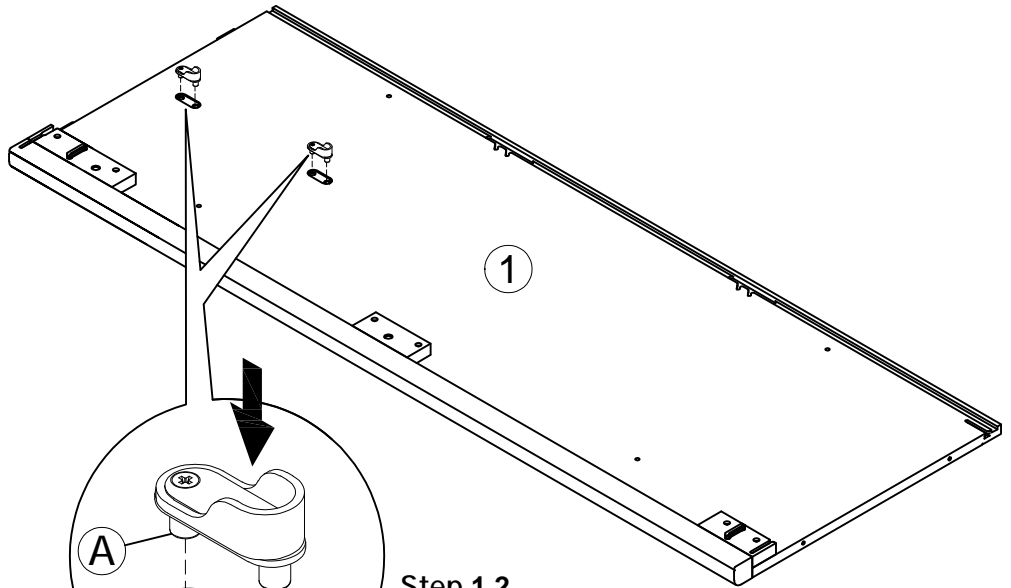

Step 1.2

Note : ensure proper alignment per illustration

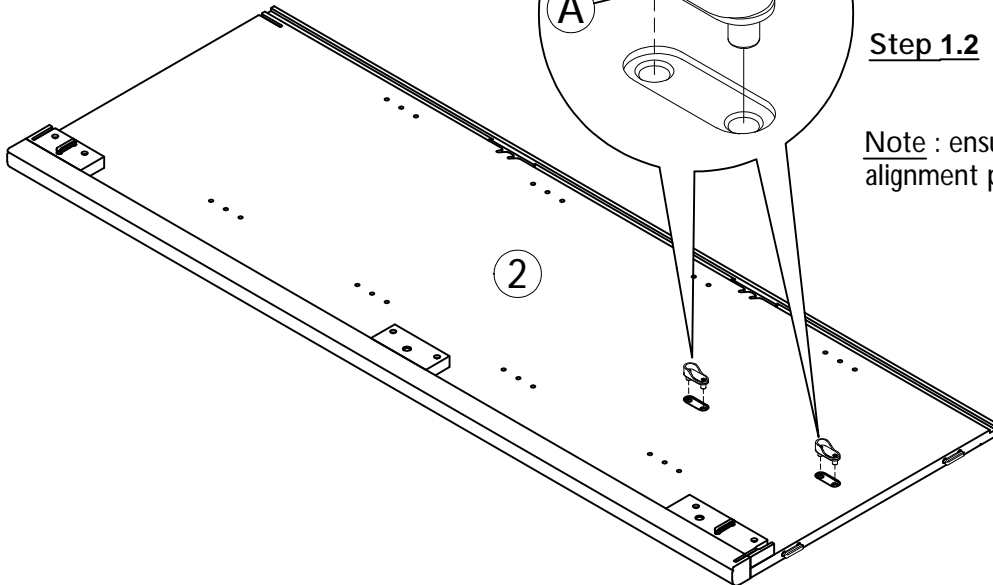

Step 1.2

Note : ensure proper alignment per illustration

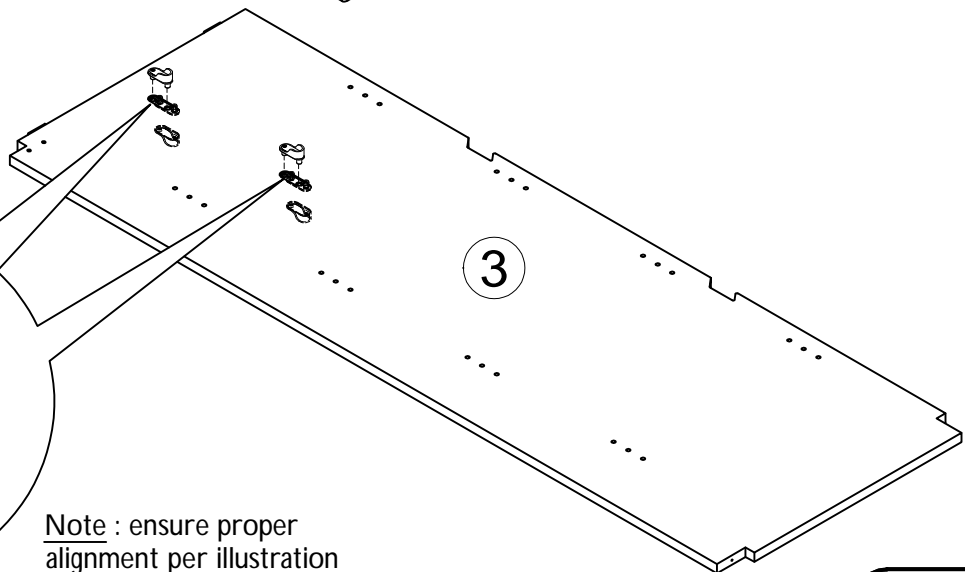

Page : 4

Step by step assembly instructions

- Step 2**
- 2.1 : Take the honeycomb sheet marked in the packaging, fold it as shown, lay the side frame left (1) and side frame right (2) sideways on the support panels as shown.
 - 2.2 : Attach top frame (5) onto side frames (1) & (2) by inserting dowels into the corresponding slots on the top frame (5). Push the top frame (5) downward to lock dowels in place, as show.
 - 2.3 : Attach the top front rail (6) & bottom front rail (7) into the side frames (1) & (2) by inserting dowels into the corresponding slots on the side frames (1) & (2) as show. Push the top front rail (6) & bottom front rail (7) downward to lock dowels in place, as show.

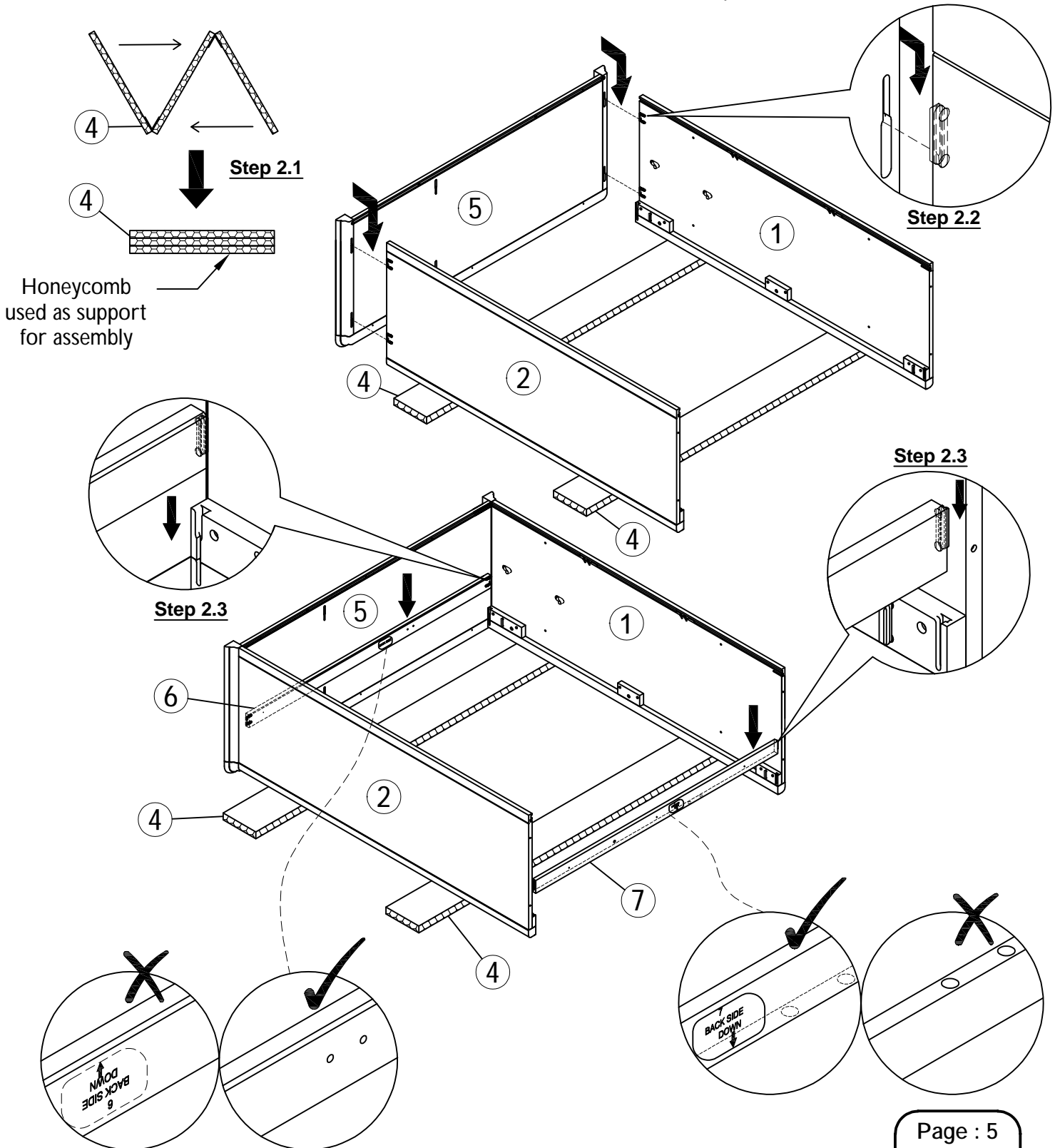

Step by step assembly instructions

- Step 3**
- 3.1 : Attach partition (3) onto top frame (5) by inserting dowels into the corresponding slots on the top frame (5). Push the partition (3) downward to lock dowels in place, as show.
 - 3.2 : Show push out side frames (1) & (2) slightly to insert middle back rails (8). Attach 2x middle back rails (8) into side frames (1) & (2), as show. Push the middle back rails (8) to "lock dowels slide pins" in place.
 - 3.3 : Attach bottom back rail (9) onto side frames (1) & (2) by inserting dowels into the corresponding slots on the side frames (1) & (2). Push the bottom back rail (9) forward to lock dowels in place, as show.

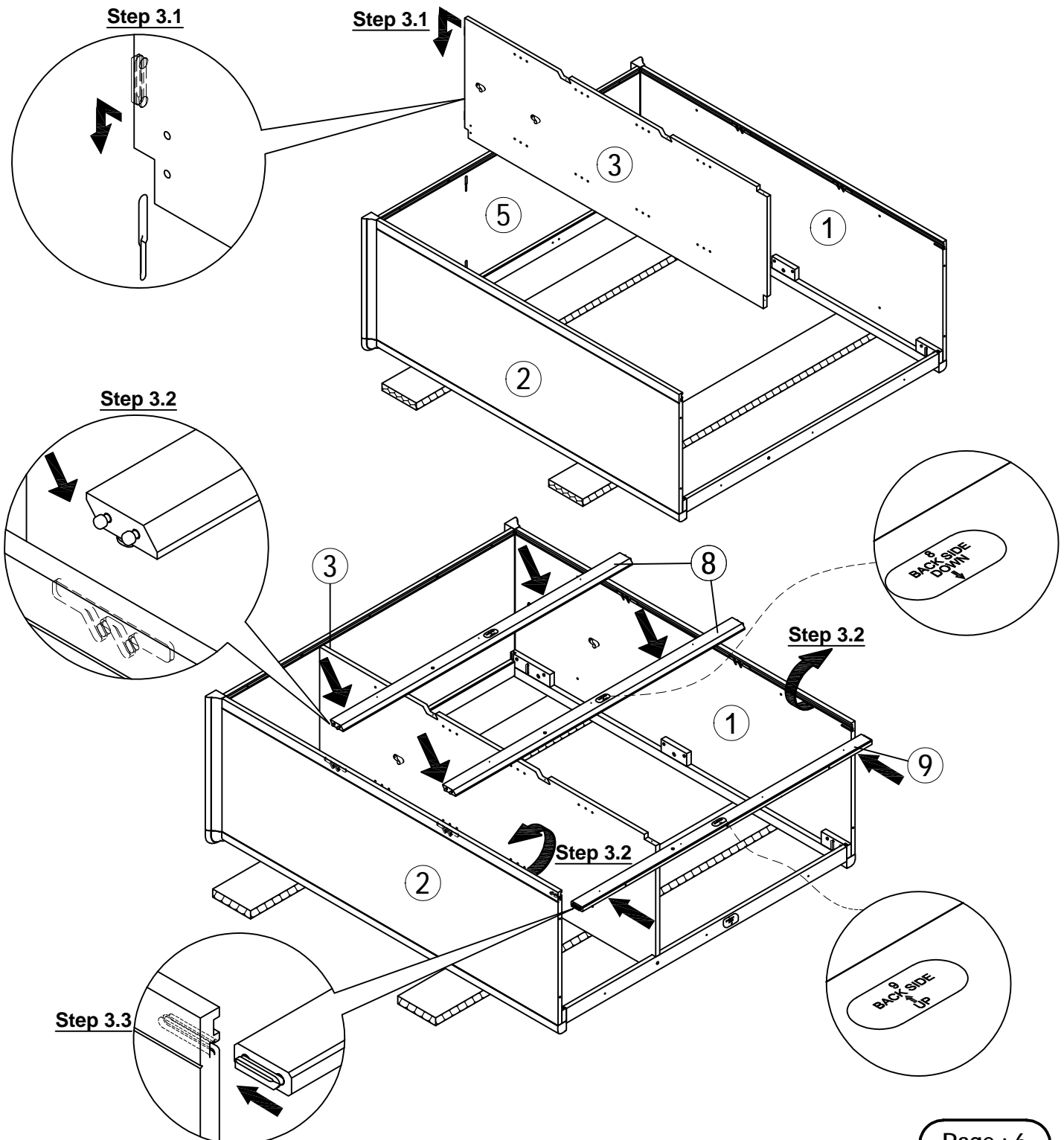

Step by step assembly instructions

- Step 4**
- 4.1 : Secure middle back rails (8), bottom back rail (9), bottom front rail (7) to partition (3) using 4x Hi-Lo screws (B) as shown. Use a pozi screwdriver to turn fittings (B) clockwise fix.
 - 4.2 : Attach 1x back panel A (10) onto the structure assembled step 4.1 as shown. Ensure back panel A (10) is inserted into the groove in the side frames and spring pins is inserted correctly into the drilled holes.
 - 4.3 : Continue, attach 1x back panel A (10) and back panel B (11) onto the structure assembled step 4.1 as shown. Ensure the back panels are inserted into the groove in the side frames and spring pins are inserted correctly into the drilled holes.
- Note: Make sure there is no gap between back panels when pushing the panels in.

Fitting



B x 4

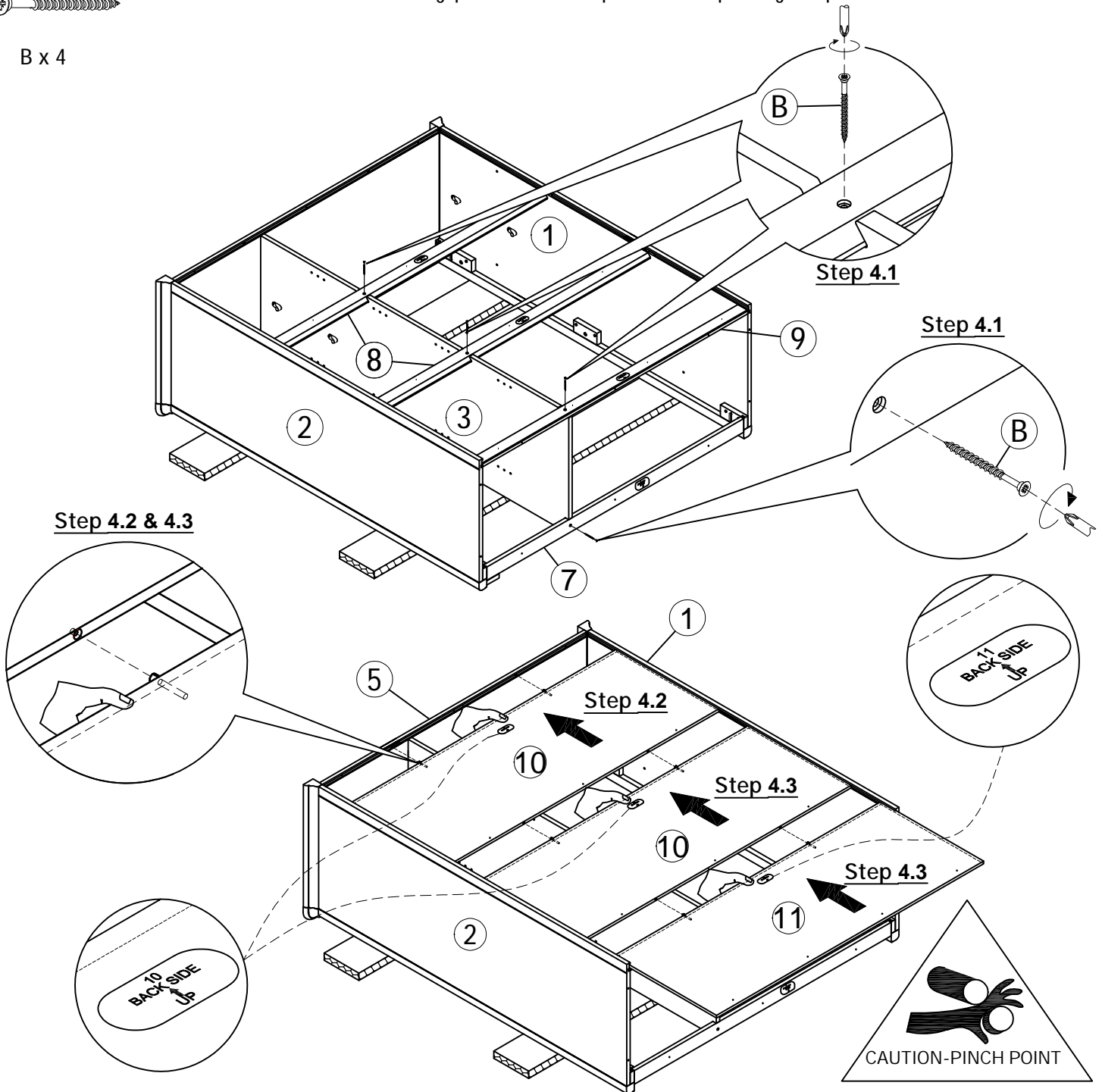

Step by step assembly instructions

- Step 5**
- 5.1 : Secure top frame (5) to 1x part (10) and part (6) using 3x Hi-Lo screws (B) and 3x round head screws (C) as shown. Use a pozi screwdriver to turn fittings (B), (C) clockwise fix.
 - 5.2 : Secure parts (10) & (11) to parts (8) and part (9) using 10x round head screws (C) as shown. Use a pozi screwdriver to turn fittings (C) clockwise fix.
 - 5.3 : Stand the unit up right.

Fitting



B x 3



C x 13

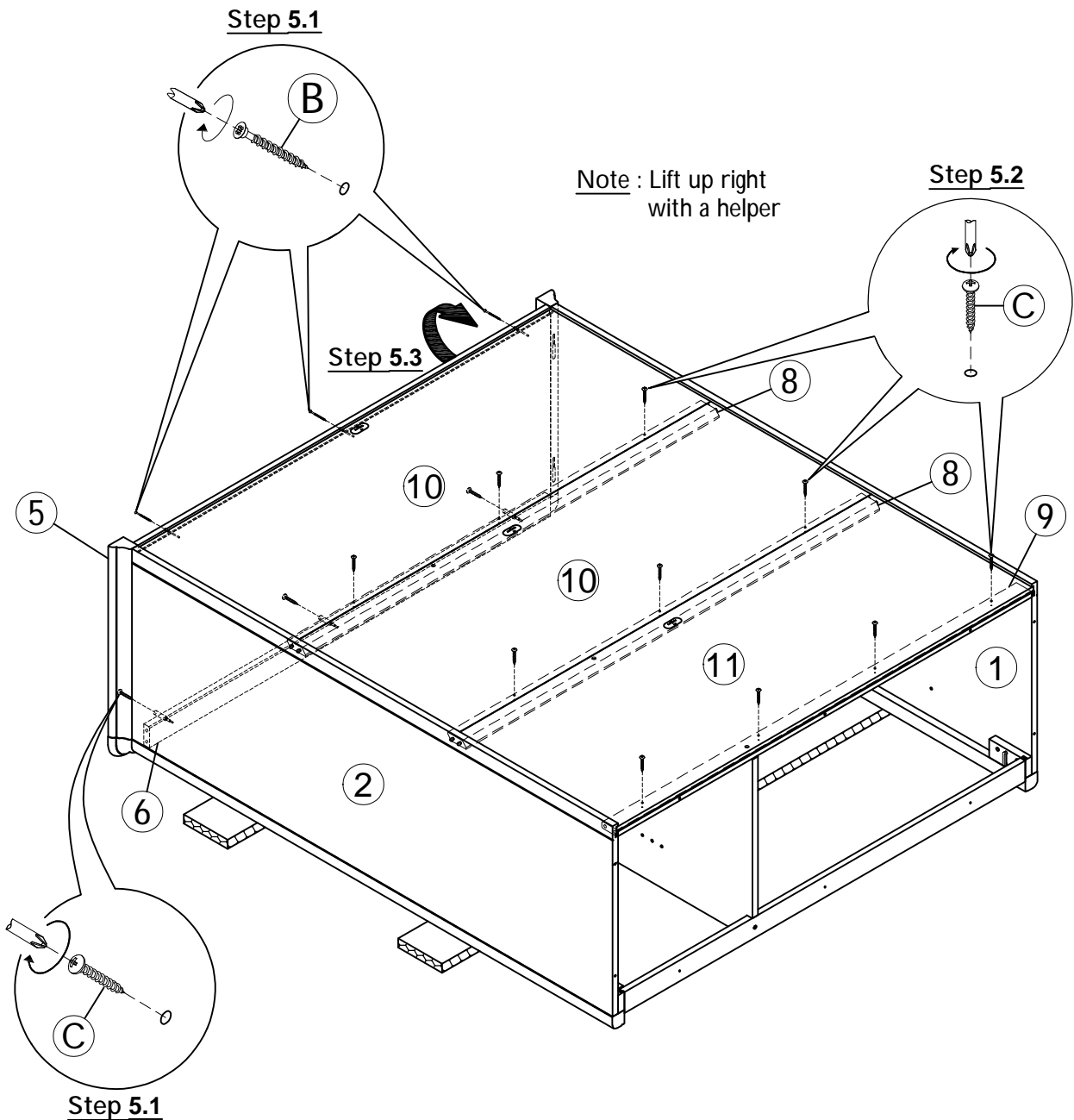

Step by step assembly instructions

- Step 6** 6.1 : Attach door stopper (12) into the pre-drilled holes onto top front rail (6) as shown.
6.2 : Attach support door stopper (13) into the pre-drilled holes onto partition (3) as shown.

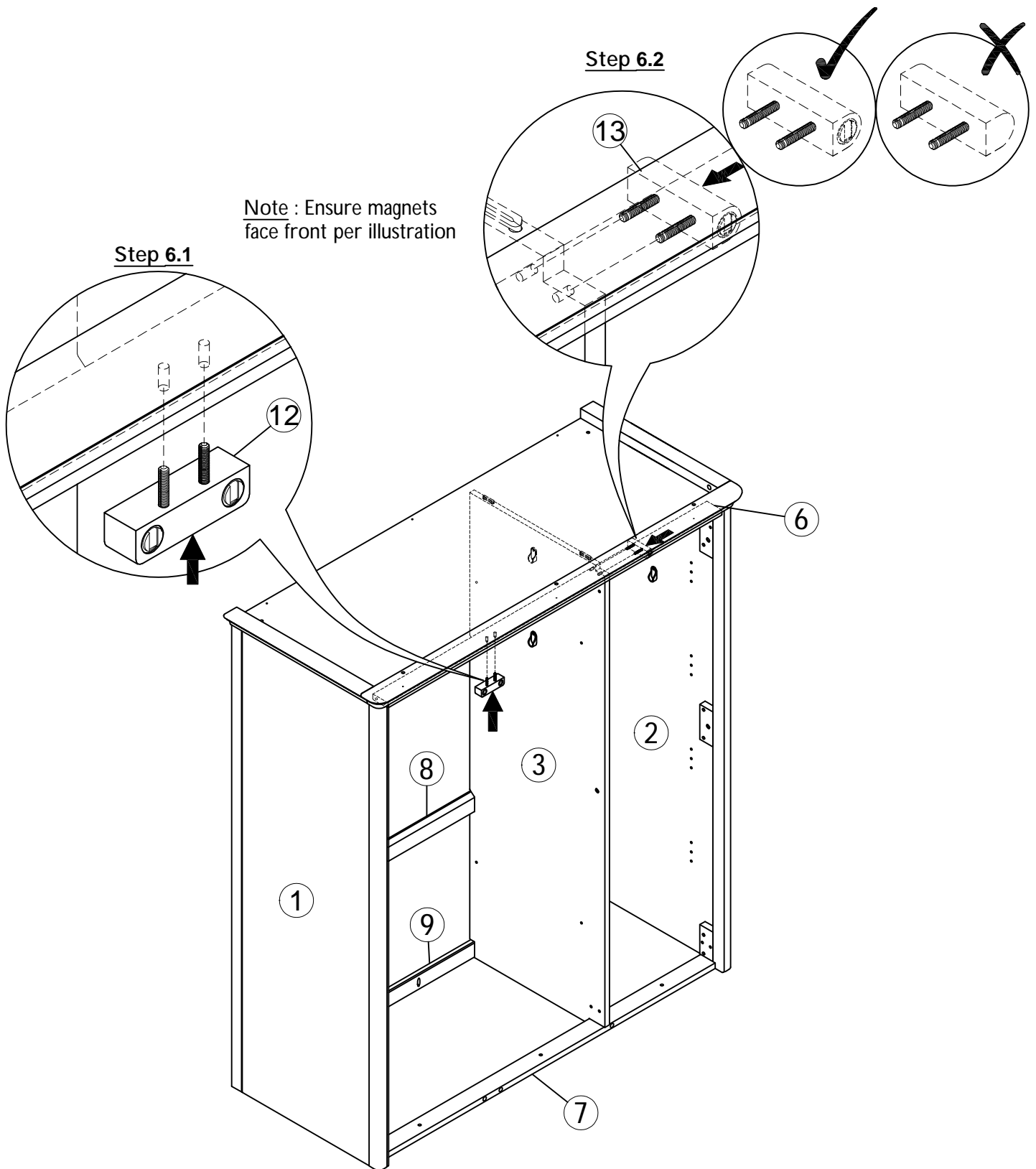

Step by step assembly instructions

Step 7 7.1: Remove the plastic from 4x felts (D) and stick felts (D) onto under of part (14) as shown.
7.2 : Stand the triple wardrobe base upright.

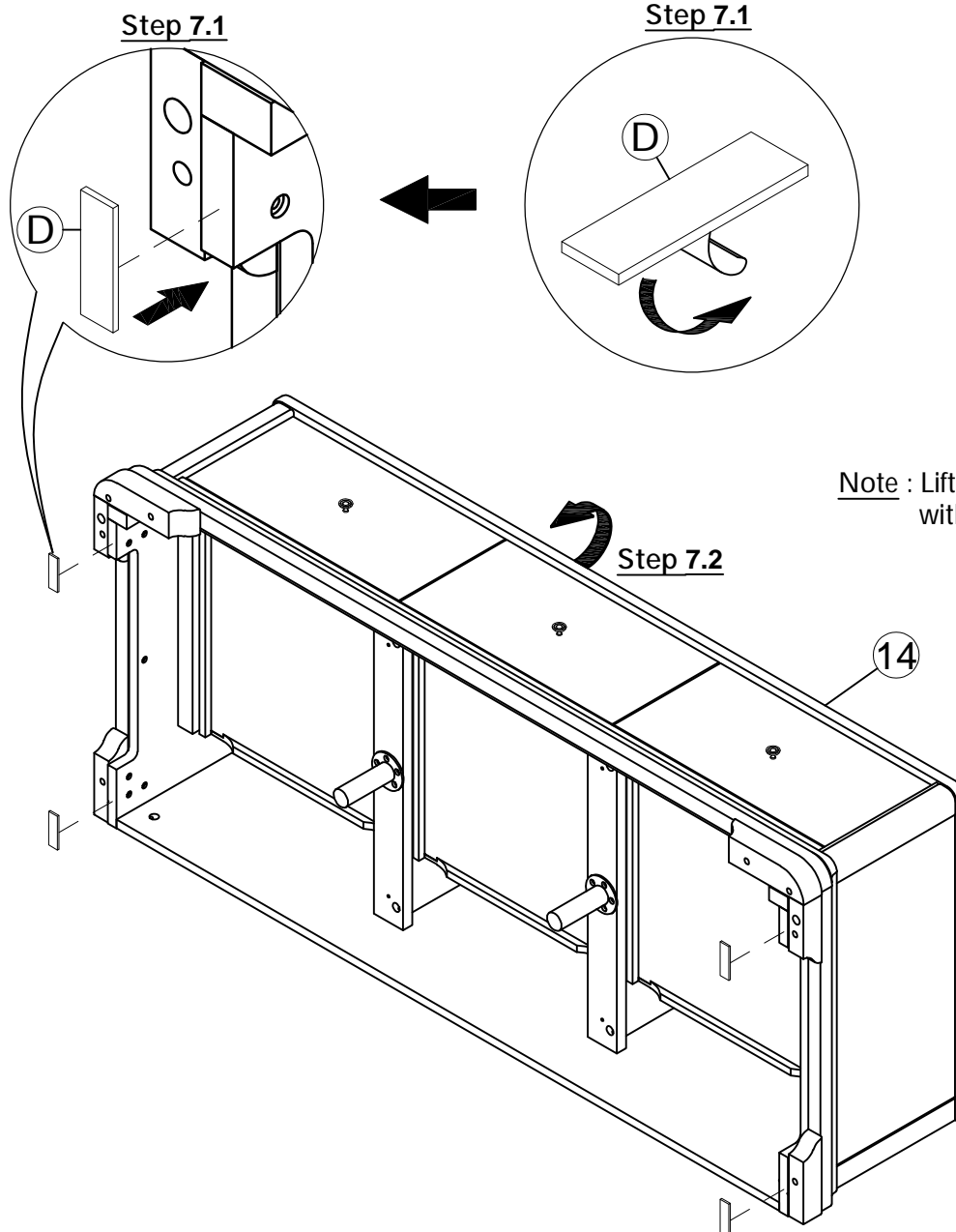
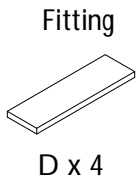

Step by step assembly instructions

- Step 8** **Note:** This product is heavy, it should be assembled as near as possible to the point of use.
- : With help of assistant, carefully lift the triple wardrobe top upwards over the triple wardrobe base (14).
 - : Carefully lower wardrobe top onto triple wardrobe base (14). Ensure the holes under triple wardrobe top are aligned correctly with the mating spring pins on triple wardrobe base (14) to avoid damage as shown.

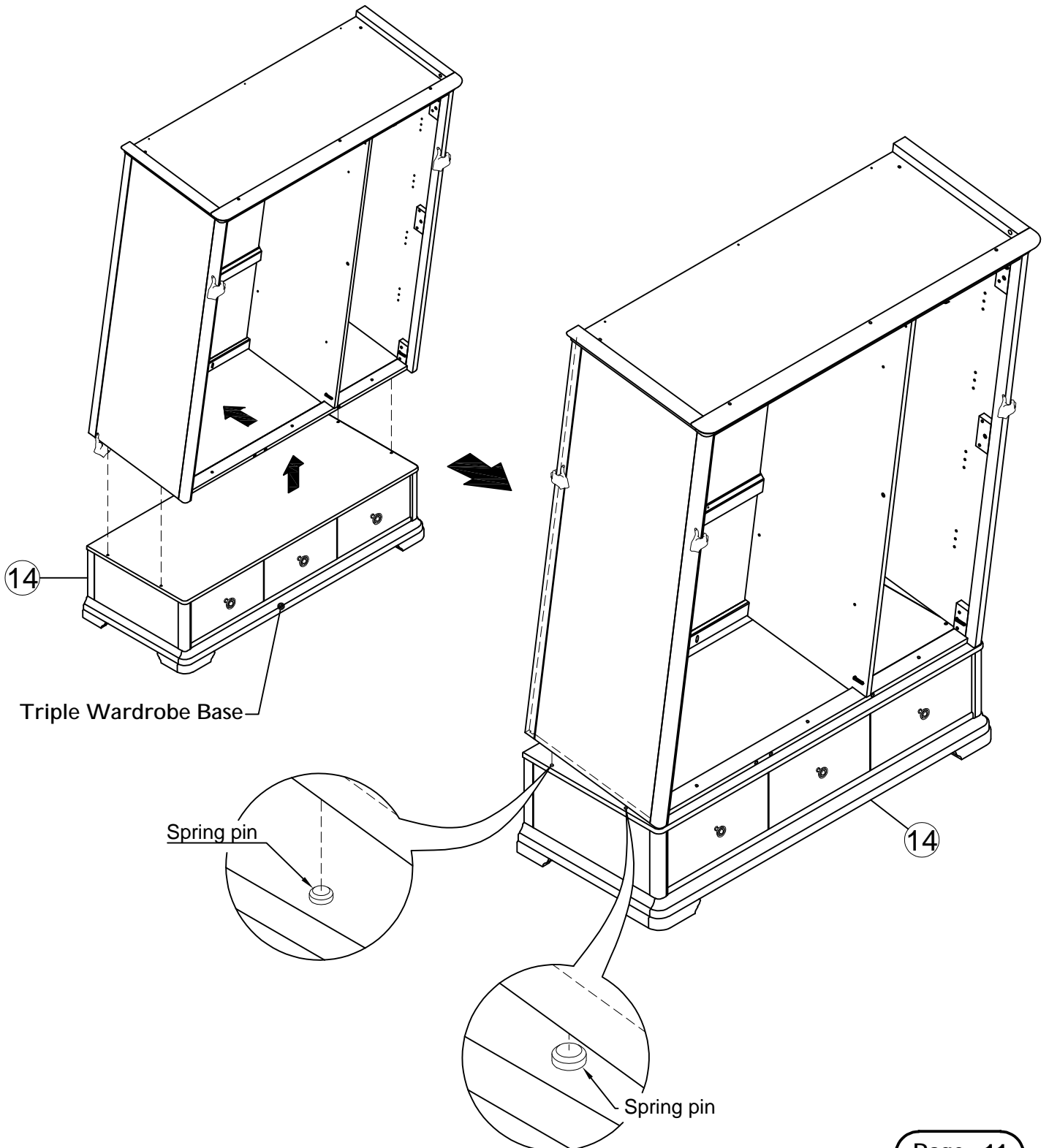

Step by step assembly instructions

Step 9 Secure triple wardrobe top to triple wardrobe base by screwing 6x round head screws (C) into the pre-drilled holes on bottom front rail (7) and bottom back rail (9) as shown. Use a screwdriver to turn fittings (C) clockwise to fix.

Fitting

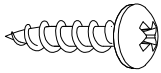

C x 6

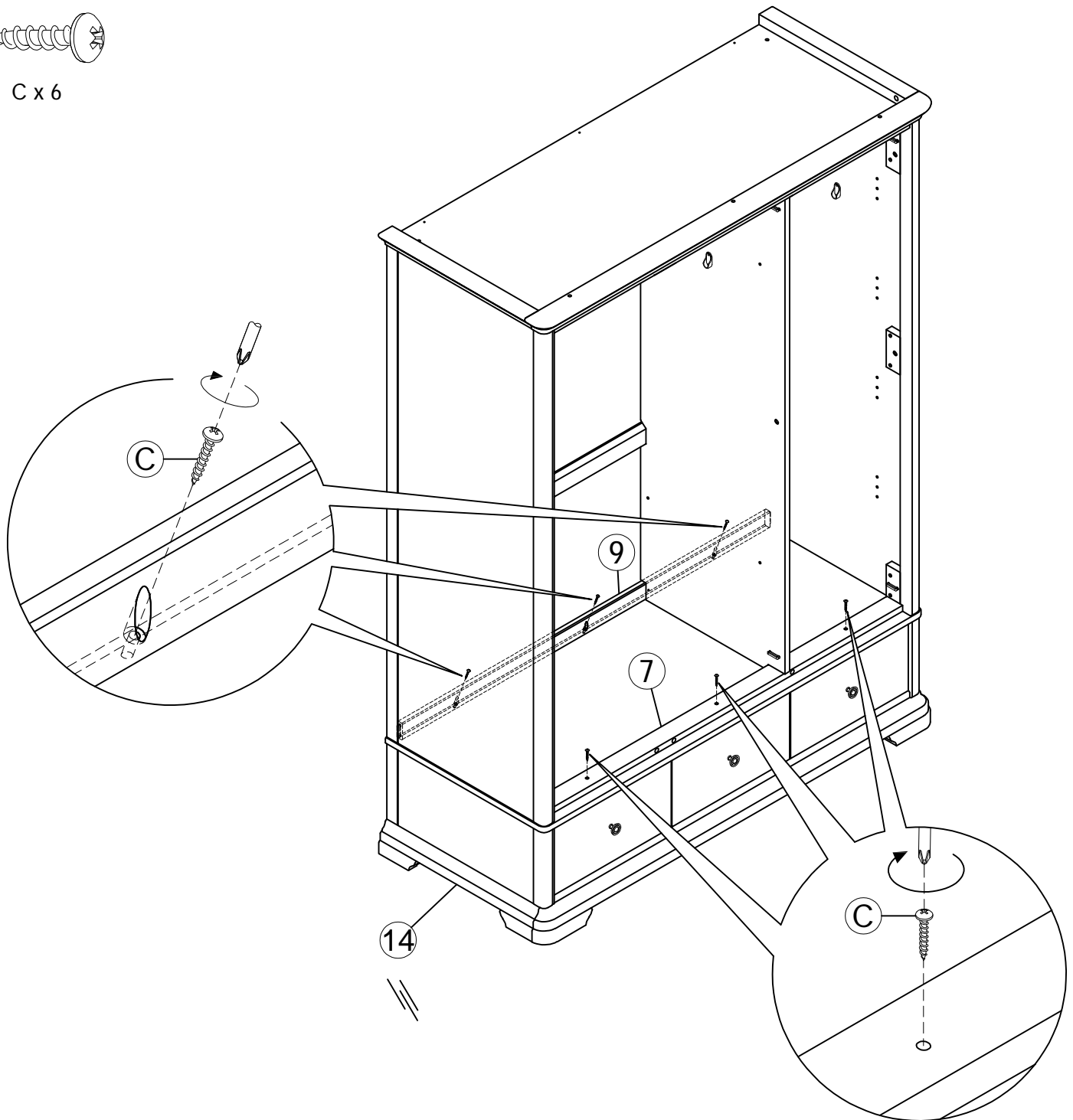

Step by step assembly instructions

Step 10 Attach doors (15), (16), (17) to side frames (1) & (2) and partition (3) by inserting dowels into the corresponding slots on doors (15), (16), (17) as shown. Ensure dowels are locked in place.

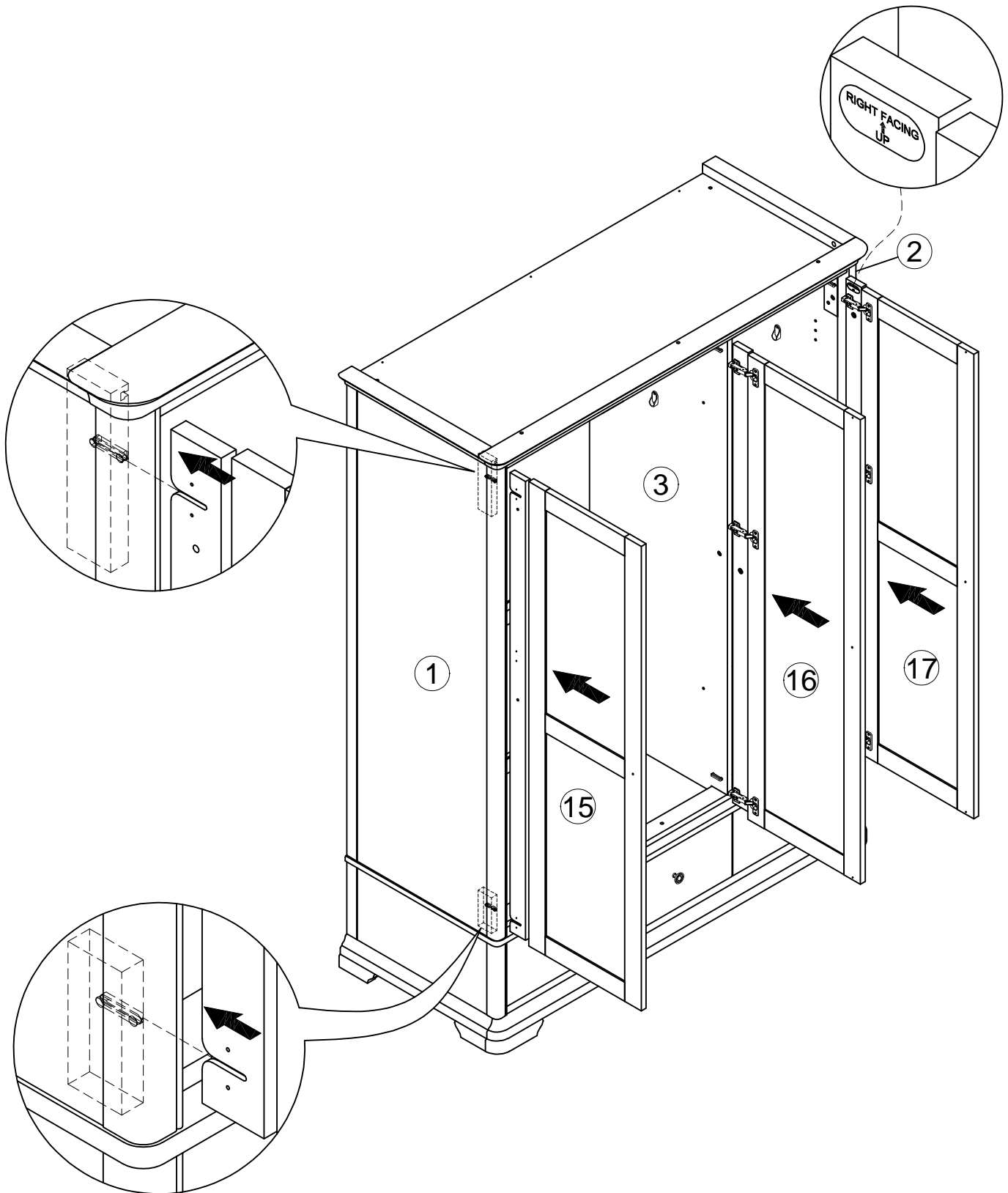

Step by step assembly instructions

Step 11

Secure doors (15), (16), (17) to sides frames (1), (2) and partition (3) using 5x hex head bolts (E) into the recessed fittings located on parts (1), (2), (3) as shown. Make sure the holes on the doors are properly aligned with the holes on the side frames (1), (2), (3) before attaching. Use allen key (F) to turn the fittings (E) clockwise to fix.

Fitting

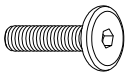

E x 5

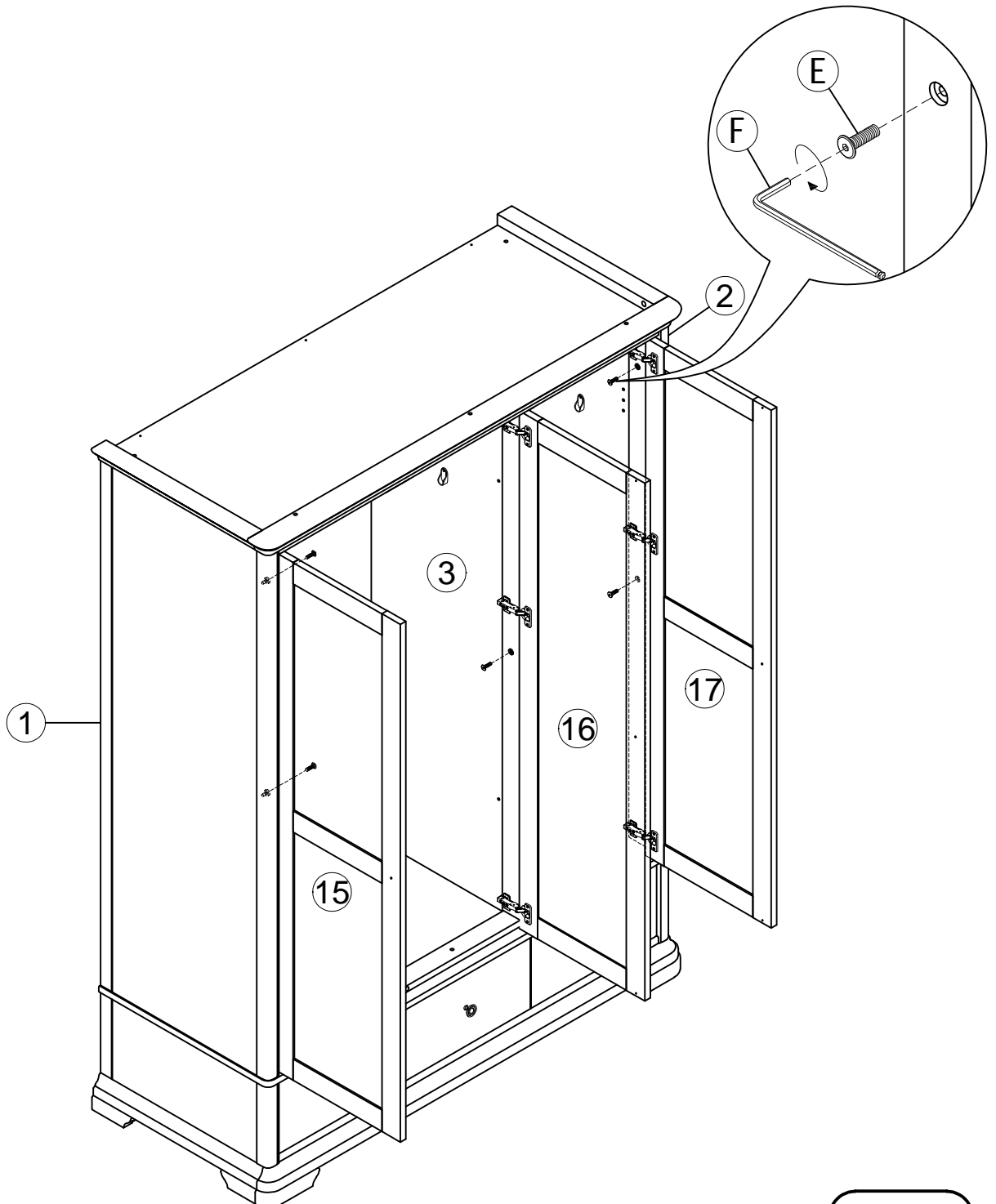

Step by step assembly instructions

- Step 12** 12.1 : Screw 2x shelf pins (G) into the insert fittings in side frame left (1) as shown.
12.2 : Tilt removable shelf frame (18) to a suitable angle as shown in the picture so as to slide it in.
12.3 : Slide removable shelf frame (18) into the unit. Ensure the holes on removable shelf frame (18) are facing down, then lower the left side of part (18) onto the pins of shelf pins (G) as shown.

Fitting



G x 2

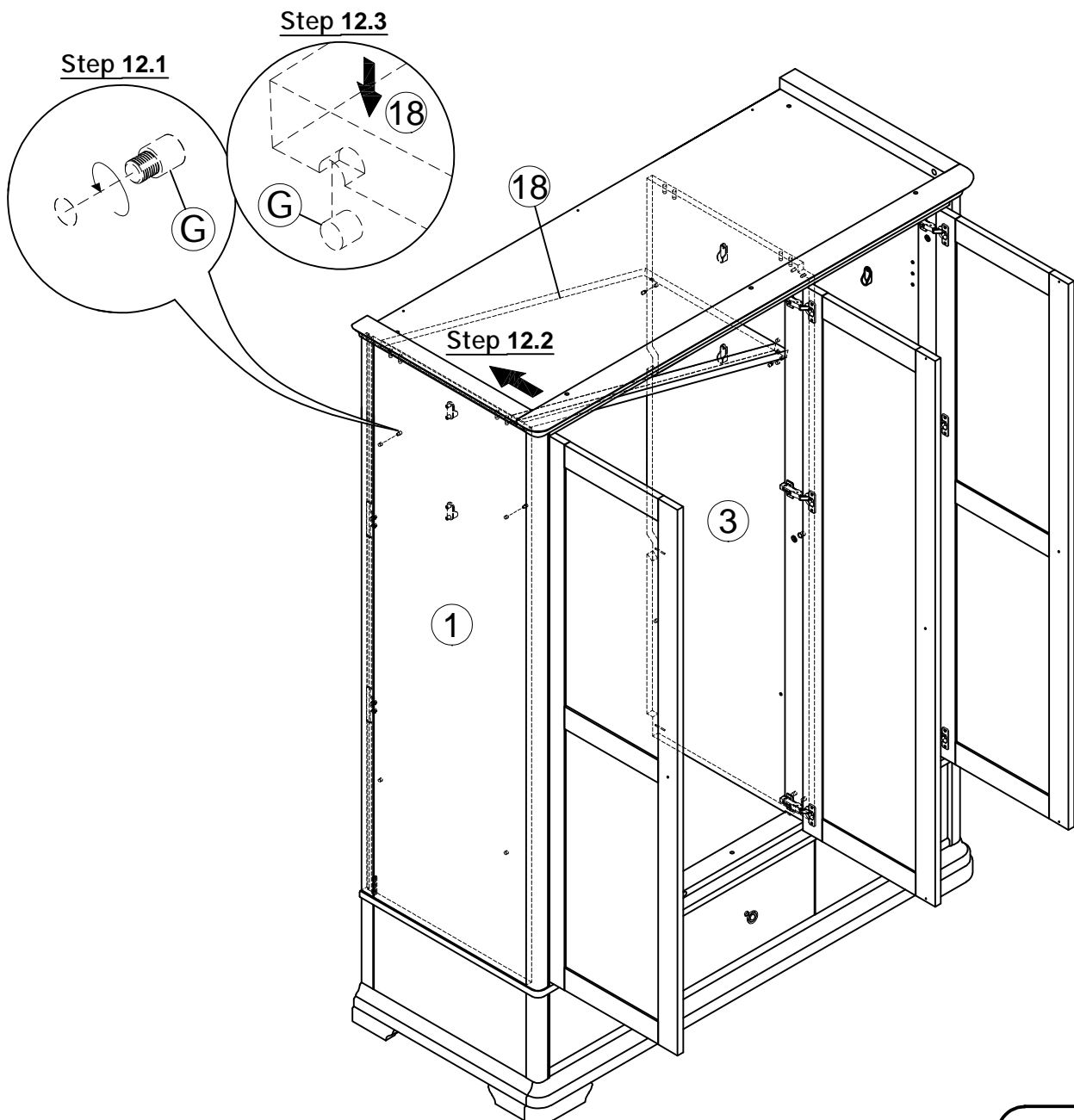

Step by step assembly instructions

Step 12 Continue

12.4 : Lift up right side of removable shelf frame (18).

12.5 : Screw 2x shelf pins (G) into the insert fittings in partition (3) as shown.

12.6 : Lower removable shelf frame (18) onto the pins of shelf pins (G) as shown.

Fitting



G x 2

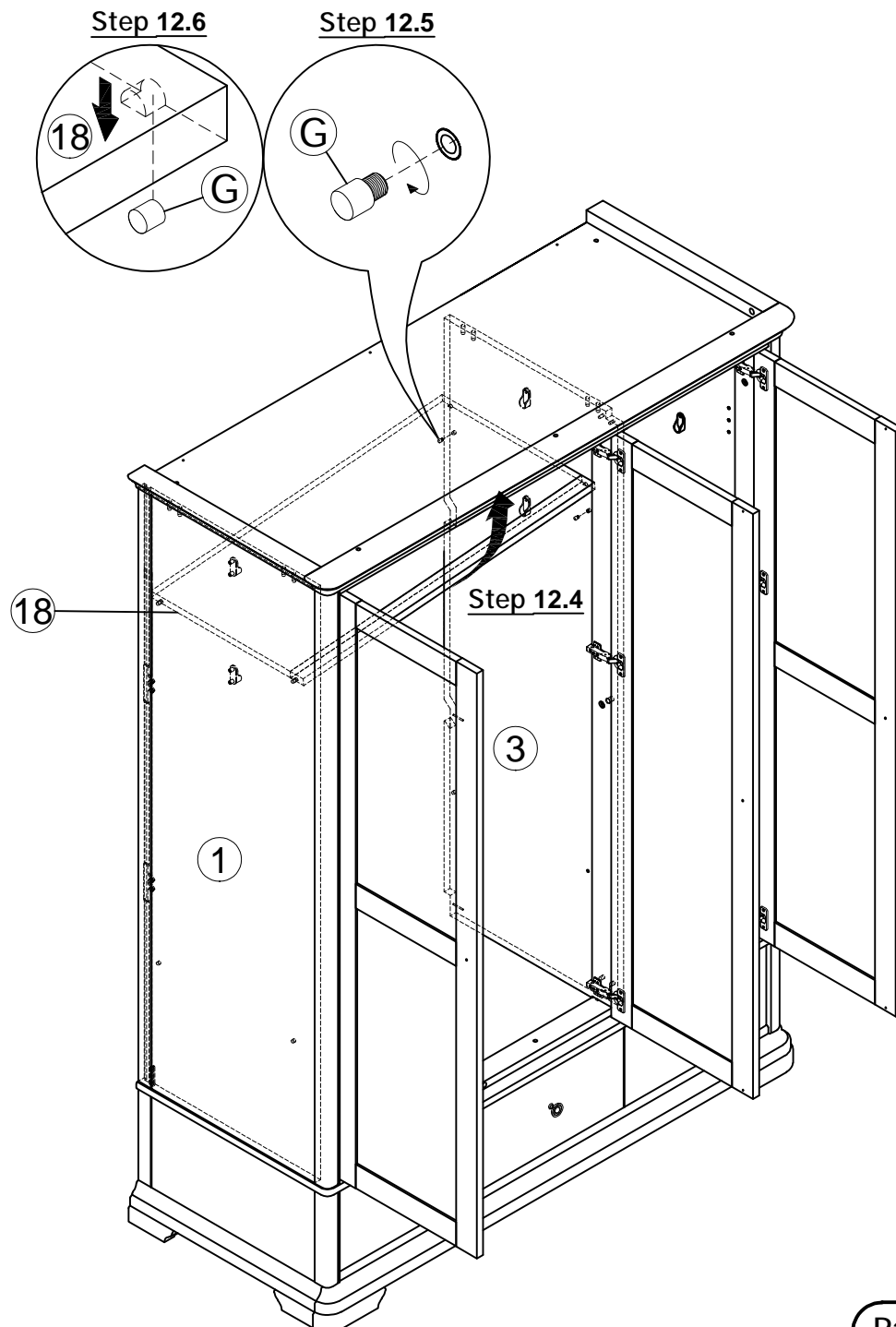

Step by step assembly instructions

- Step 13** 13.1 : Screw 8x shelf pins (G) into the insert fittings in side frame right (2) as shown.
13.2 : Tilt adjustable shelf (19) to a suitable angle as shown in the picture so as to slide it in.
13.3 : Slide adjustable shelf (19) into the unit. Ensure the holes on adjustable shelf (19) are facing down, then lower the left side of parts (19) onto the pins of shelf pins (G) as shown.

Fitting



G x 8

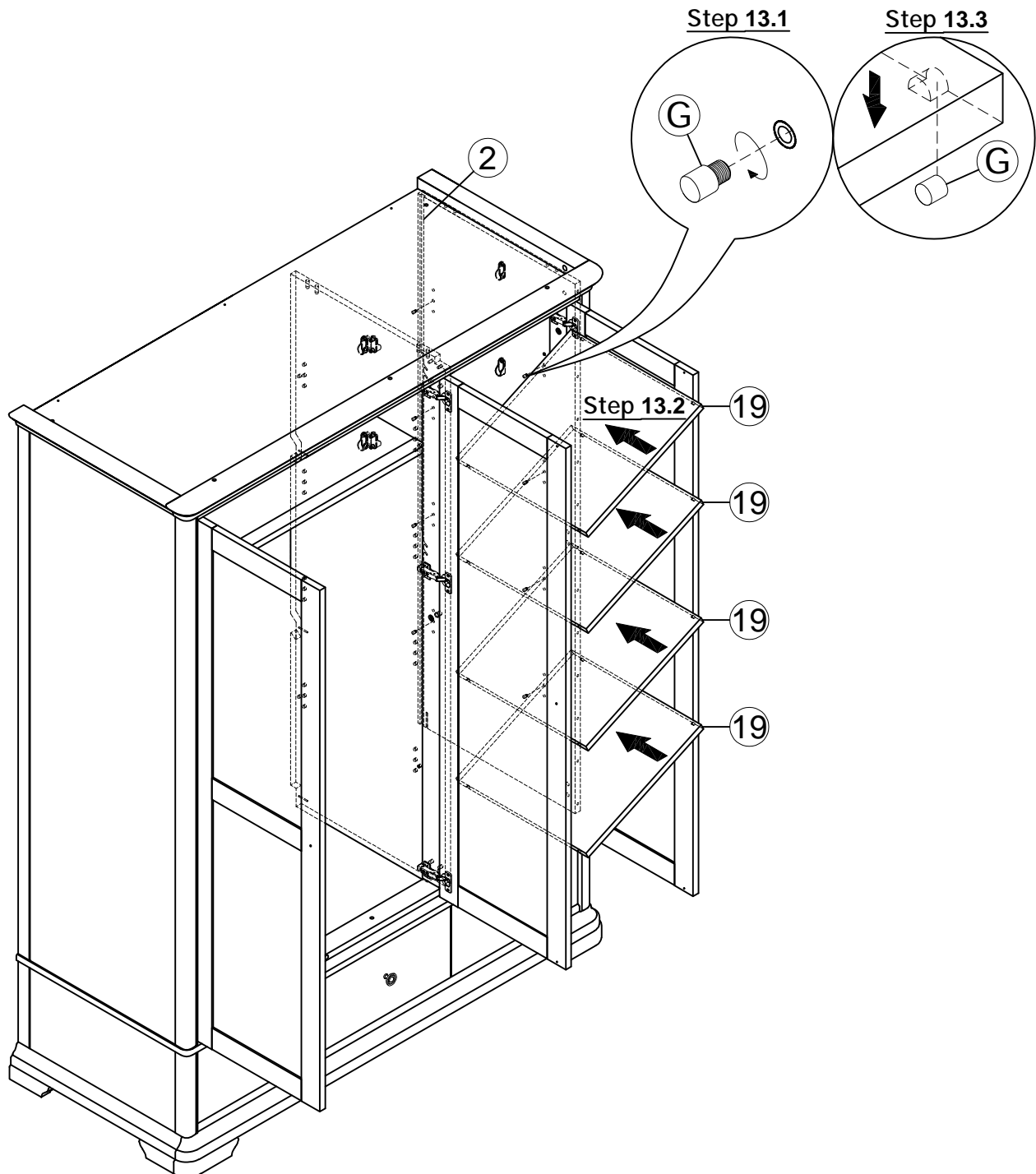

Step by step assembly instructions

Step 13 Continue

13.4 : Lift up left side of adjustable shelf (19).

13.5 : Screw 8x shelf pins (G) into the insert fittings in partition (3) as shown.

13.6 : Lower adjustable shelf (19) onto the pins of shelf pins (G) as shown.

Fitting



G x 8

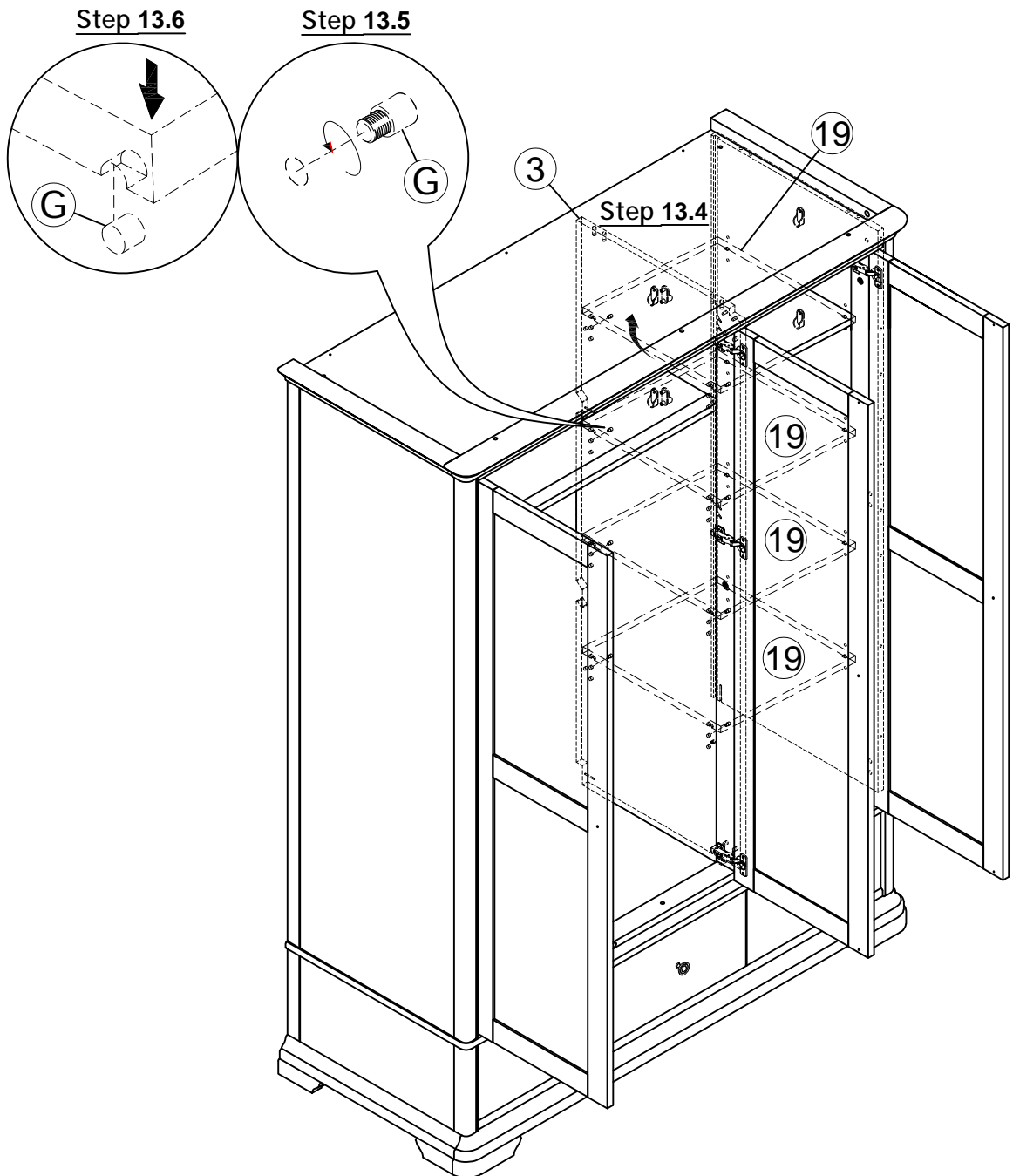

Step by step assembly instructions

Step 14 14.1 : Attach 3x handles (L) to the front of doors (15), (16), (17) using 3x round head bolts (K) as shown. Use a phillips screwdriver to turn fittings (K) clockwise to fix.

14.2 : Place 1x long clothes rail bar (J) onto hanger rail supports (A) on side frame left (1) and partition (3) and 1x short clothes rail bar (H) onto hanger rail supports (A) on side frame right (2) and partition (3) as show.

Note : clothes rail bars (J), (H) can be installed in both up and down of the cabinet.

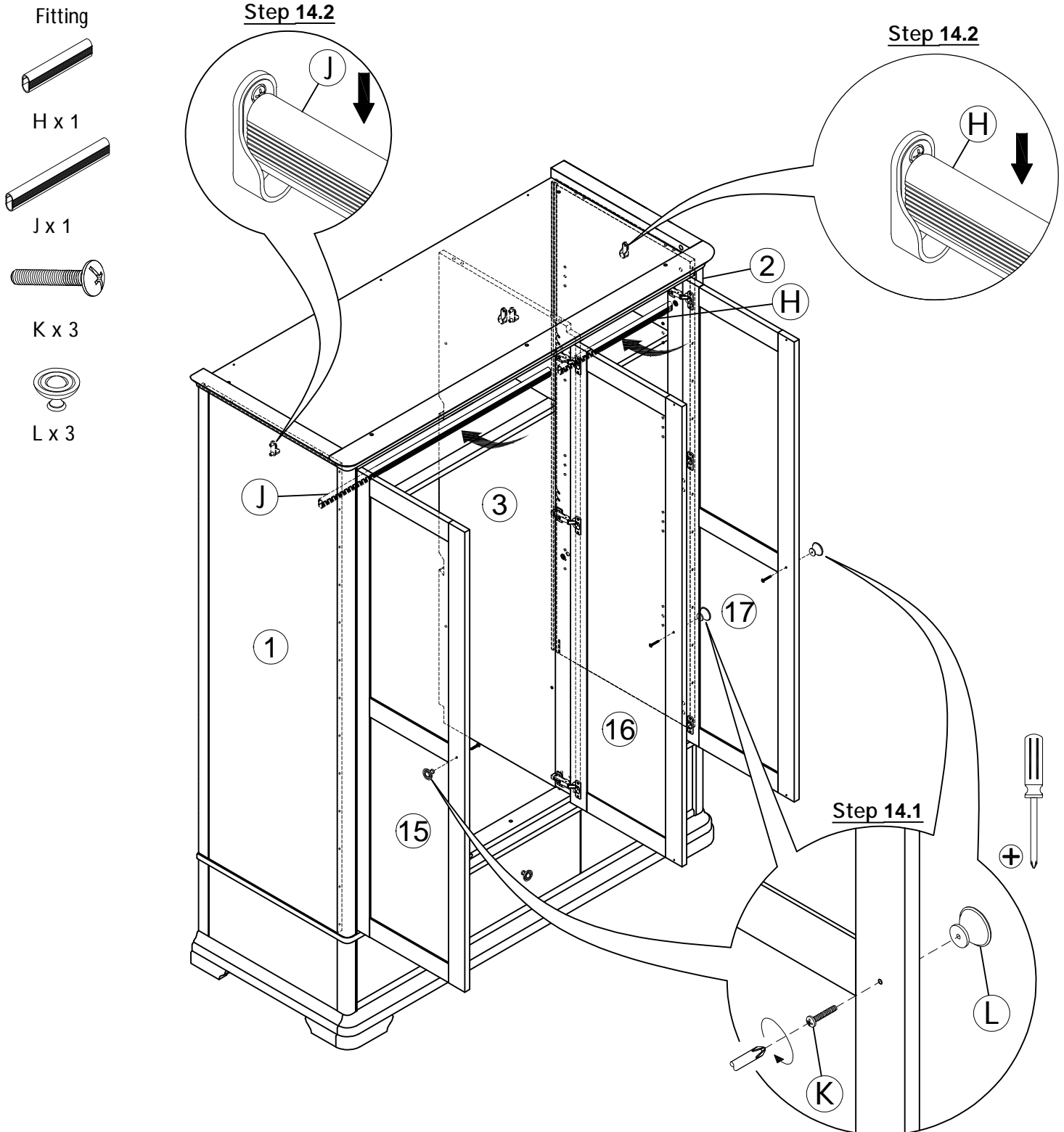

Step by step assembly instructions

Step 15 Note : The clothes rail (H), (J) and removable shelf frame (18) can be installed into the wardrobe in 2 ways as shown.

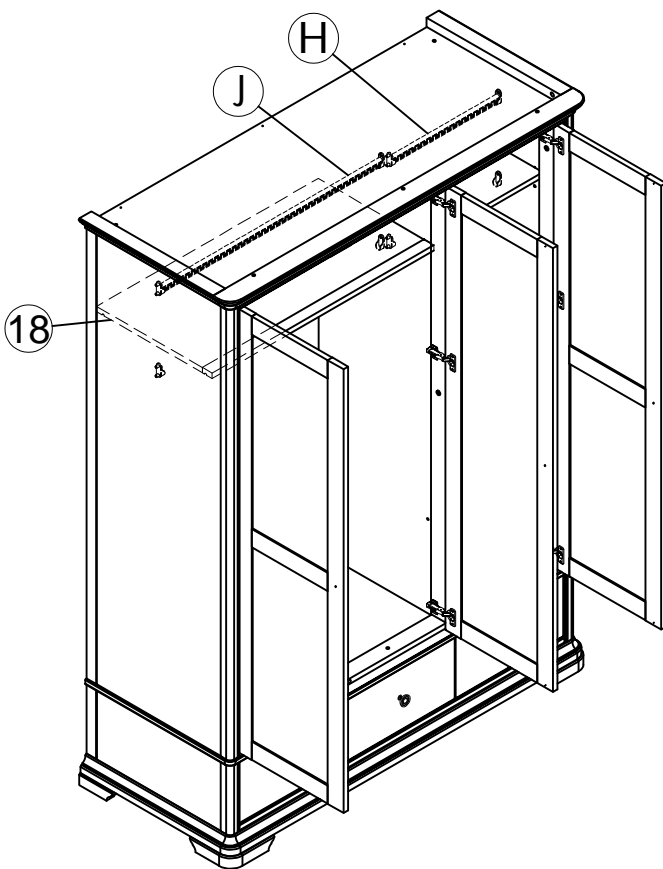

Option 1

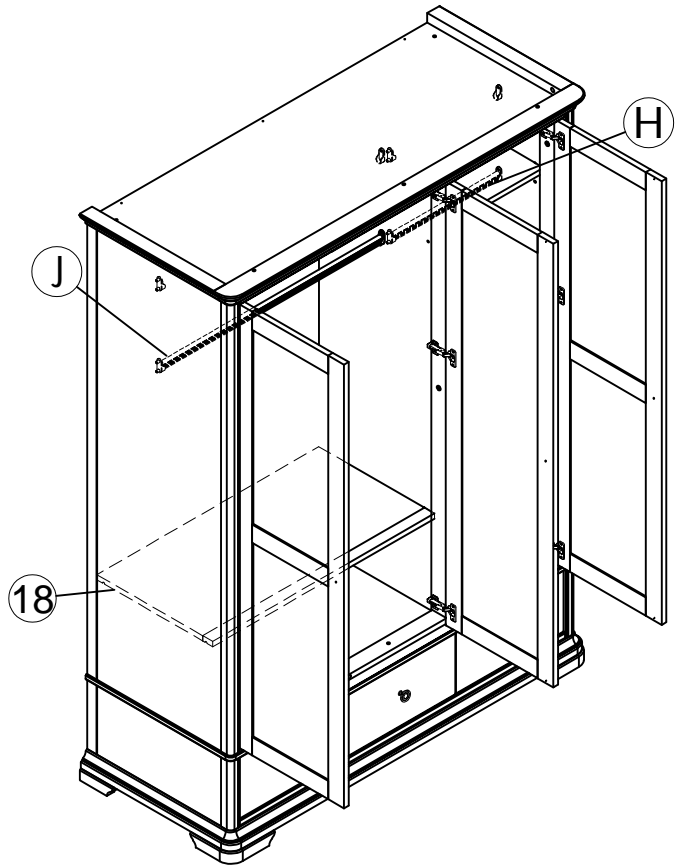

Option 2

Step by step assembly instructions

Step 16 If cabinet not level, please insert 2x plastic leveler (M) under legs as required to level and square the cabinet.

16.1 : Push 2x plastic leveler (L) in as far as you need to level the furniture.

16.2 : Then snap off the excess.

Fitting



M x 2

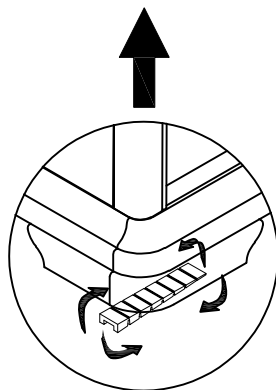
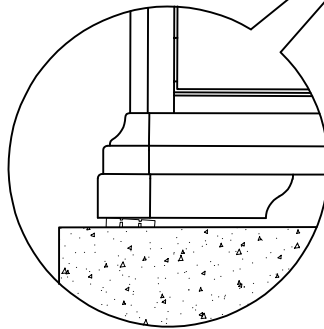
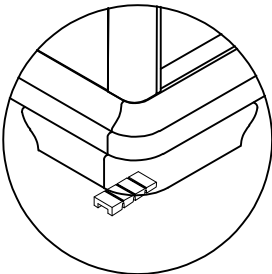
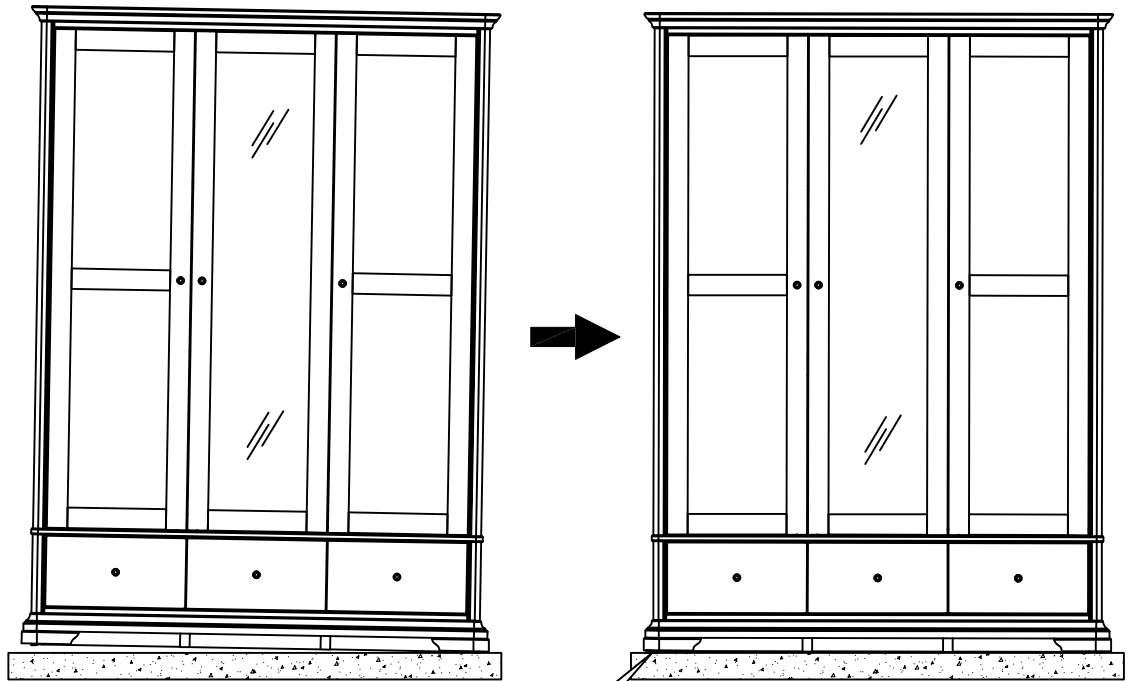

Step 16.2

Step 16.1

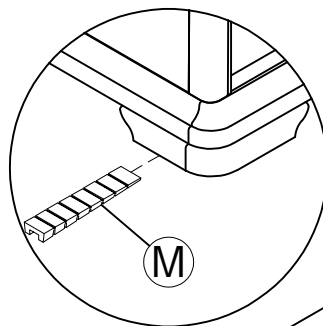

Lift one leg left or right as applicable and insert the wedge

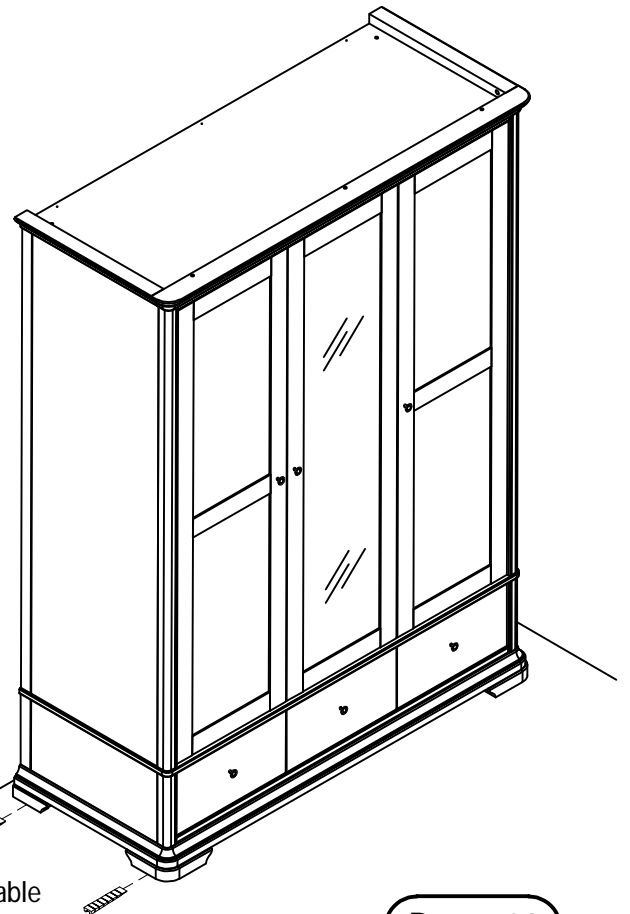

Page : 21

UNDERMOUNT DRAWER GLIDE ADJUSTMENT INSTRUCTION

ASSEMBLE

Lay the drawer bottom onto the slide then push the drawer into the cabinet

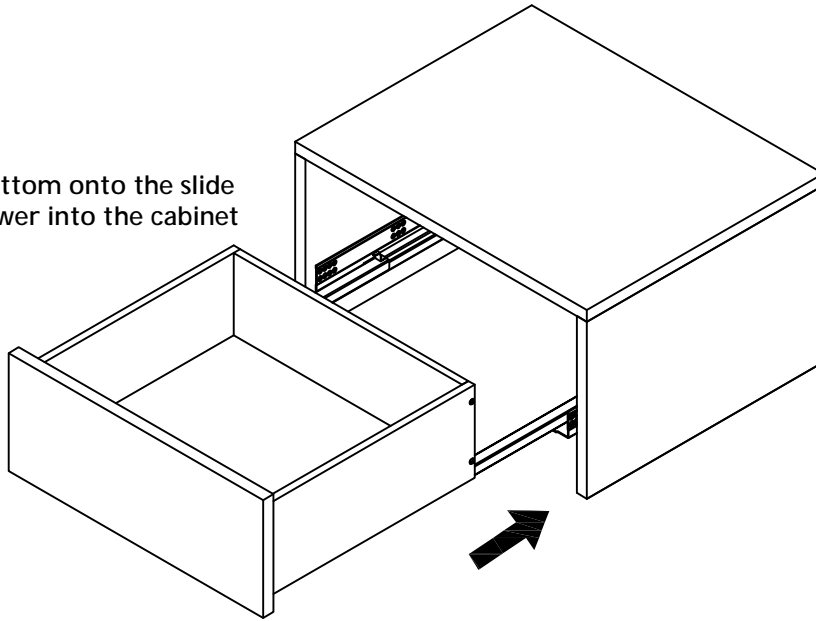

HEIGHT ADJUSTMENT

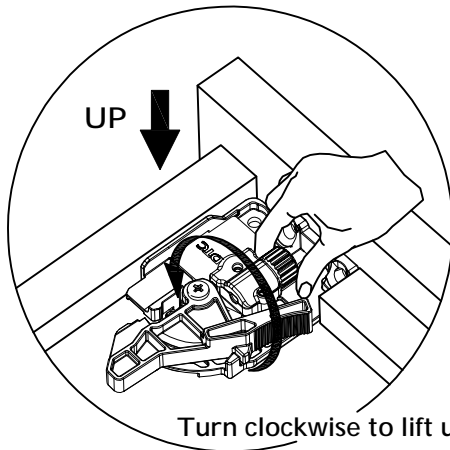

Turn clockwise to lift up

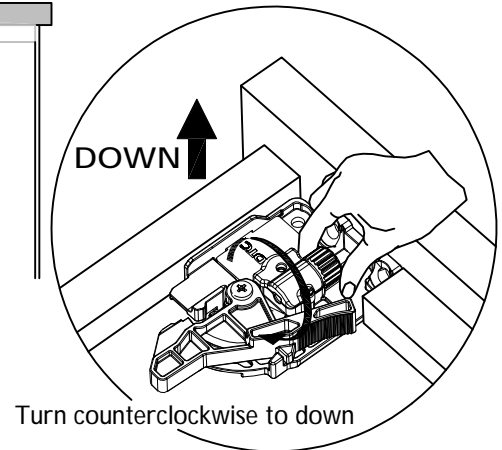
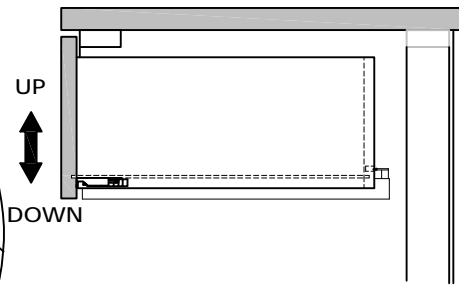

Turn counterclockwise to down

REMOVE

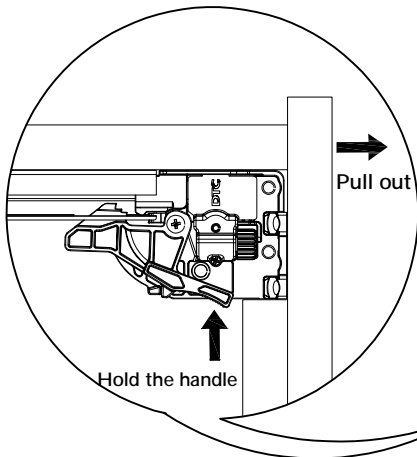

For removal, extend the runner all the way out. Unlock by hold the handle and pull out the drawer.

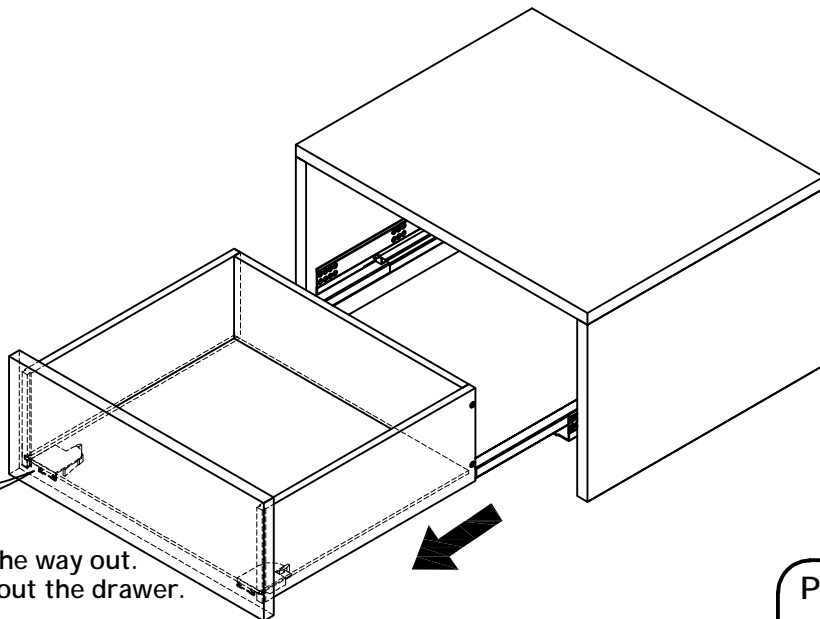

HINGE ADJUSTMENT INSTRUCTIONS

LATERAL ADJUSTMENT
by screw adjustment.

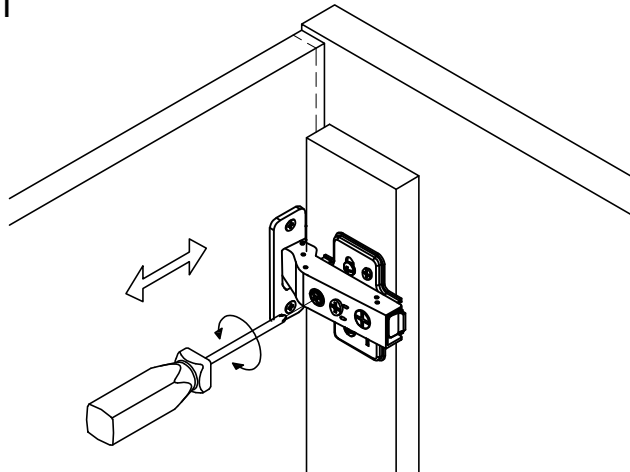

FRONT-TO-BACK
by slackening and retightening
the hinge-arm mounting screw.

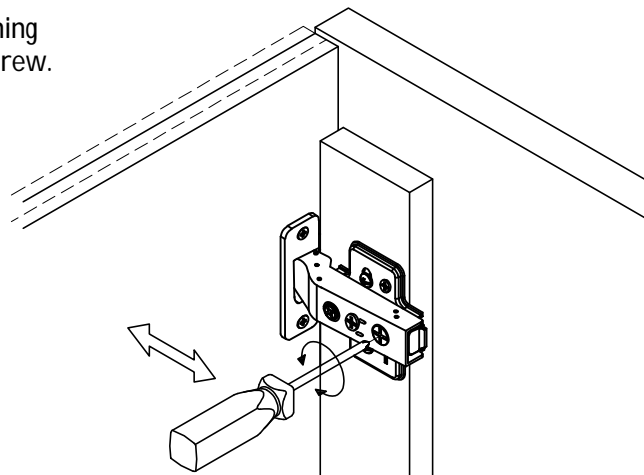

VERTICAL ADJUSTMENT
via slots on mounting plate by
slackening and retightening the
screws on mounting plate

1.1

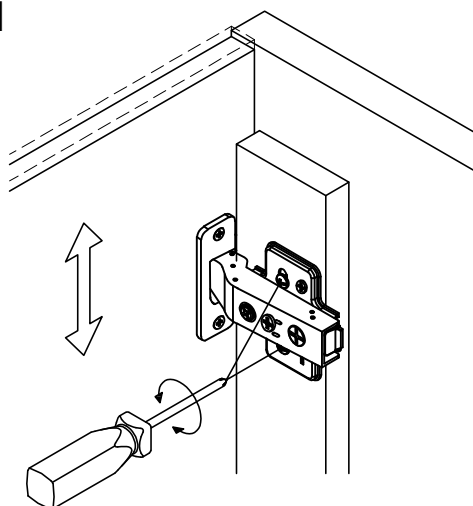

1.2

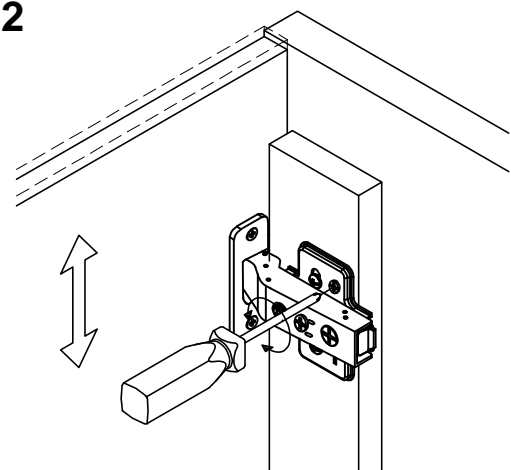

HINGE ADJUSTMENT INSTRUCTIONS

SLOW DOWN CLOSING
by screw adjustment to clockwise.

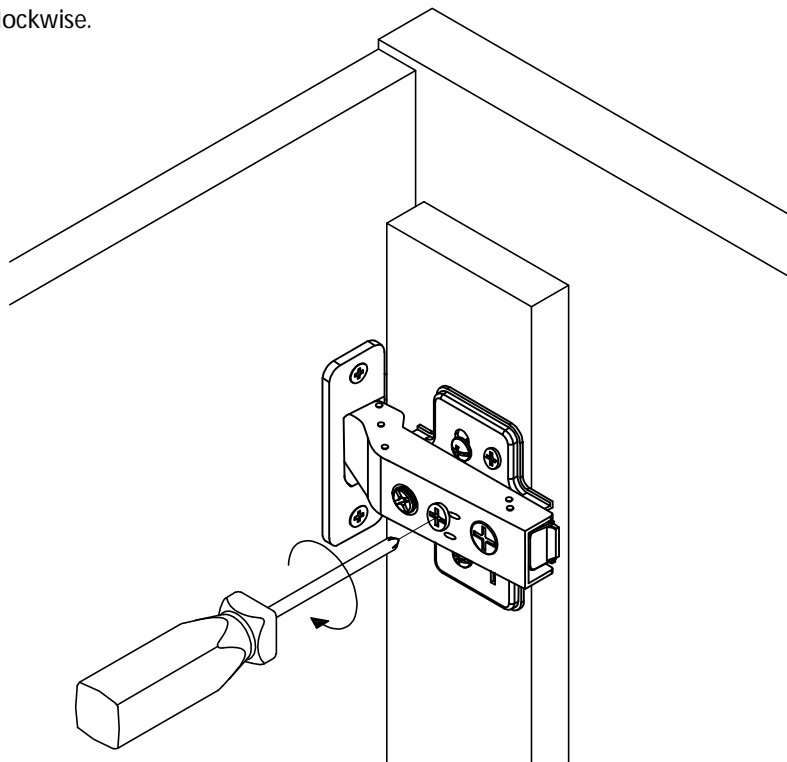

SPEED UP CLOSING
by screw adjustment to counter clockwise.

