

DOUBLE WARDROBE

Stock number: 9172-82

Thank you for purchasing this product. Please read the instructions carefully before use to ensure safe and satisfactory assembly of this product.

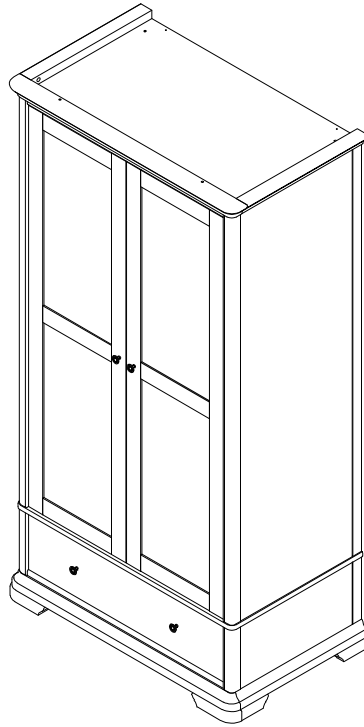

Pre-assembly preparation

Please ensure instructions are read in full before attempting to assemble this product.

Necessary Tools : Pozi screwdriver and Phillips screwdriver

(Included)

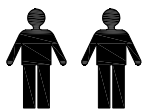

Pz 2 or Pz 3

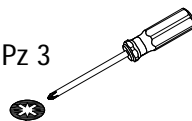

Ph 2

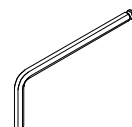

Please check the pack contents before attempting to assemble this product. A full checklist of components is given in this leaflet. If any components are missing, please contact the retailer from whom you bought this product.

This product takes approximately **30-40 MINUTES** to assemble with **2 PEOPLE**.

All assembly should be performed on a flat, stable, clean and soft surface.

This product is **HEAVY**, it should be assembled as near as possible to the point of use. **TAKE CARE WHEN LIFTING** to avoid personal injury and (or) damage to the product.





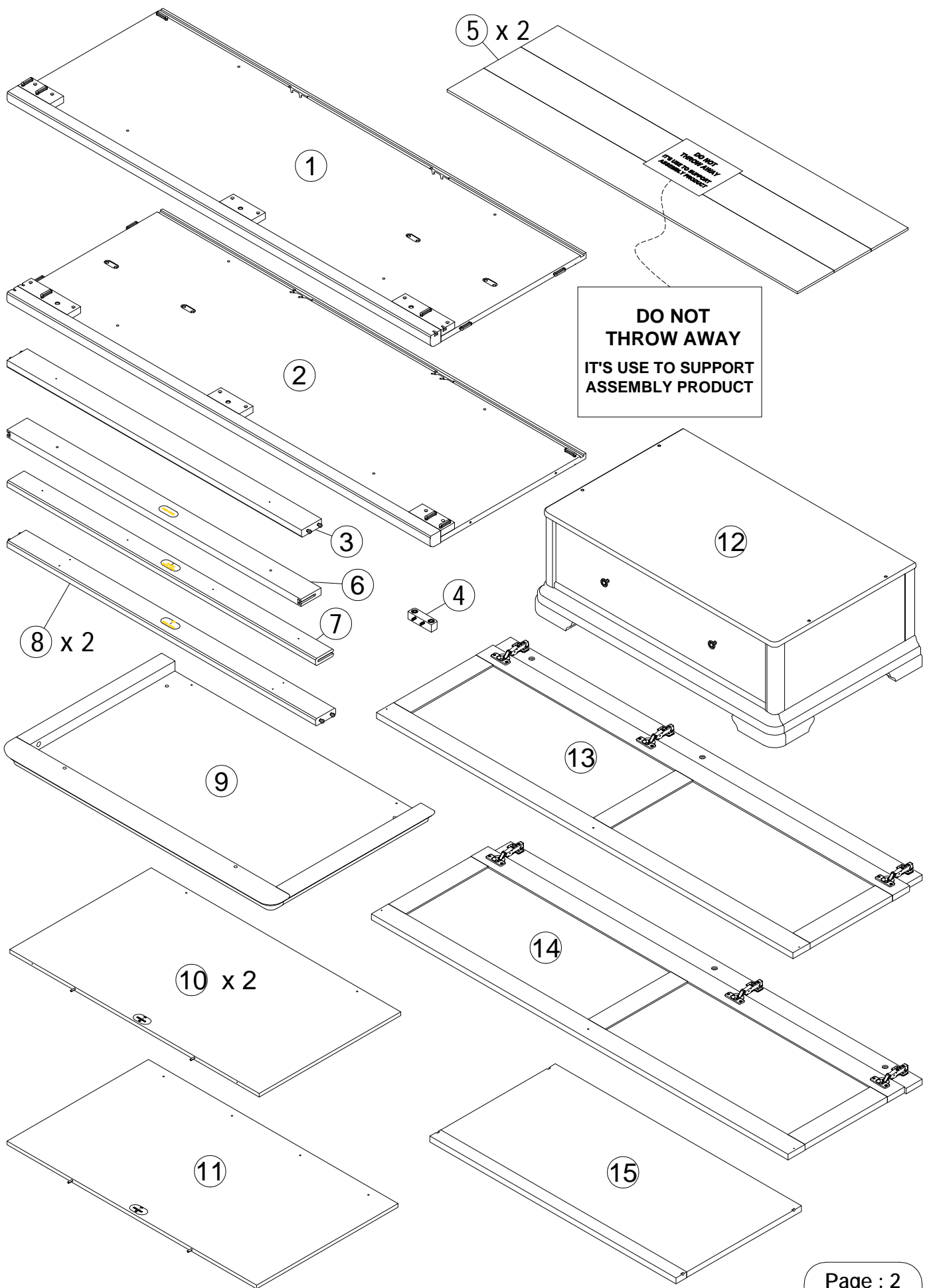



The fitting pack contains **SMALL ITEMS** which should be **KEPT AWAY FROM YOUNG CHILDREN**.

IMPORTANT: Retain these instructions for future reference.

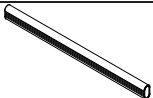
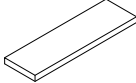

Fittings and parts checklist

Item	Description	Qty.	Item	Description	Qty.
1	Side frame right	x 1	9	Top frame	x 1
2	Side frame left	x 1	10	Back panel A	x 2
3	Top front rail	x 1	11	Back panel B	x 1
4	Door stopper	x 1	12	Double wardrobe base	x 1
5	Honeycomb used as support for Assembly	x 2	13	Door frame left	x 1
6	Bottom front rail	x 1	14	Door frame right	x 1
7	Bottom back rail	x 1	15	Removable shelf frame	x 1
8	Middle back rail	x 2			

A	Hanger rail support 20 x 14 x 50mm		x 4	G	Handle		x 2
B	Hi-Lo Screw Ø4 x 50mm		x 2	H	Round head bolt Ø4 x 28mm		x 2
C	Round head screw Ø4 x 25mm		x 14	J	Clothes rail bar		x 1
D	Felt 3 x 20 x 60mm		x 4	K	Shelf pin		x 4
E	Hex head bolt M6 x 25mm		x 4	L	Plastic Leveler		x 2
F	Allen key M4 x 30 x 110mm		x 1				

Step by step assembly instructions

- Step 1**
- 1.1 : Lay all parts onto a flat, stable, clean and soft surface.
 - 1.2 : Push 4x hanger rail supports (A) onto the pre-drilled holes on side frames (1) & (2) as shown.
 - 1.3 : Attach door stopper (4) into the pre-drilled holes onto top front rail (3) as shown.

Fitting



A x 4

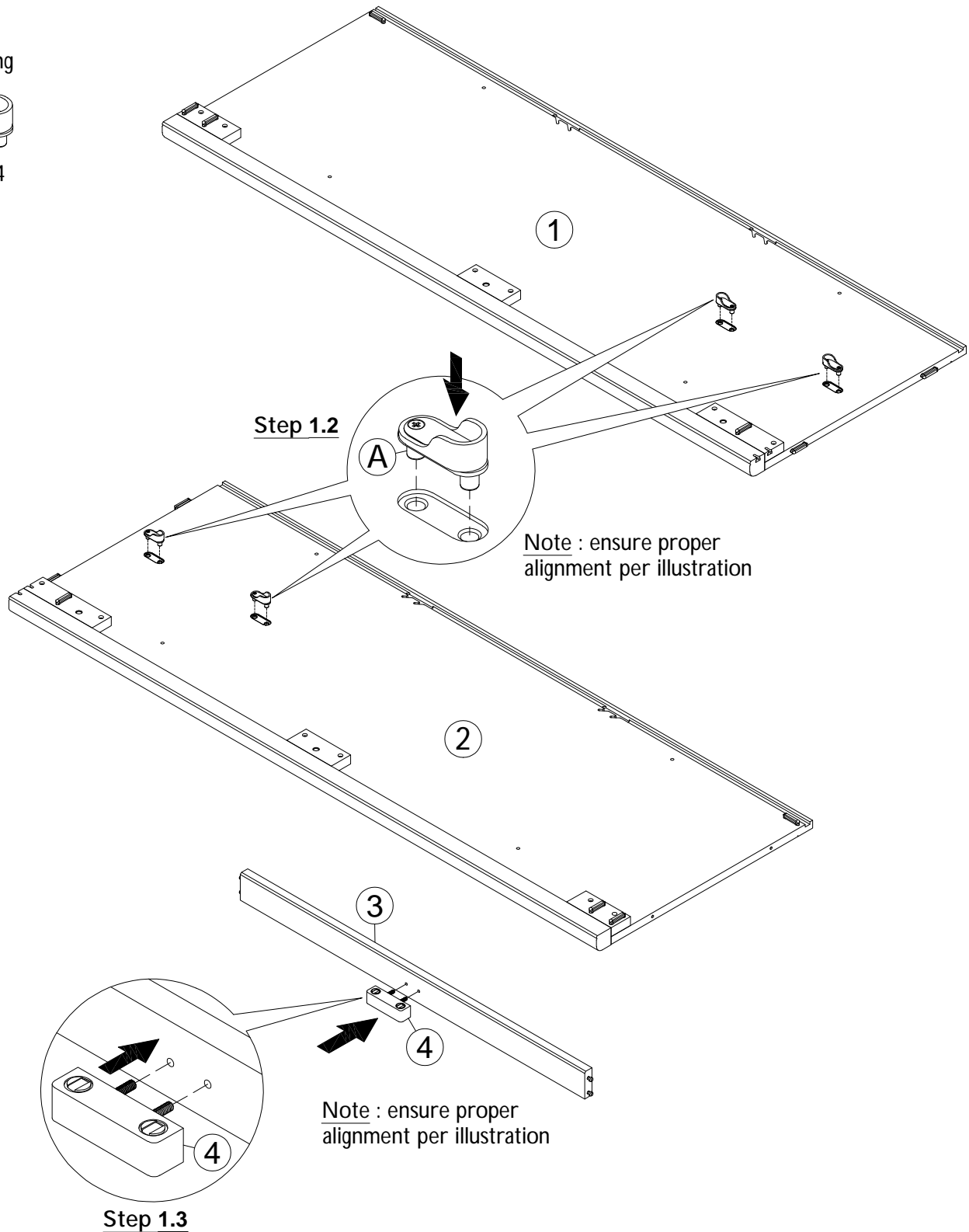

Step by step assembly instructions

- Step 2**
- 2.1 : Take the honeycomb sheet marked in the packaging, fold it as shown.
Lay the side frame right (1) and side frame left (2) sideways on the support panels as shown.
- 2.2 : Attach side frames (1) & (2) onto bottom front rail (6) by inserting dowels into the corresponding slots on the bottom front rail (6).
Push the side frames (1) & (2) downward to lock dowels in place.

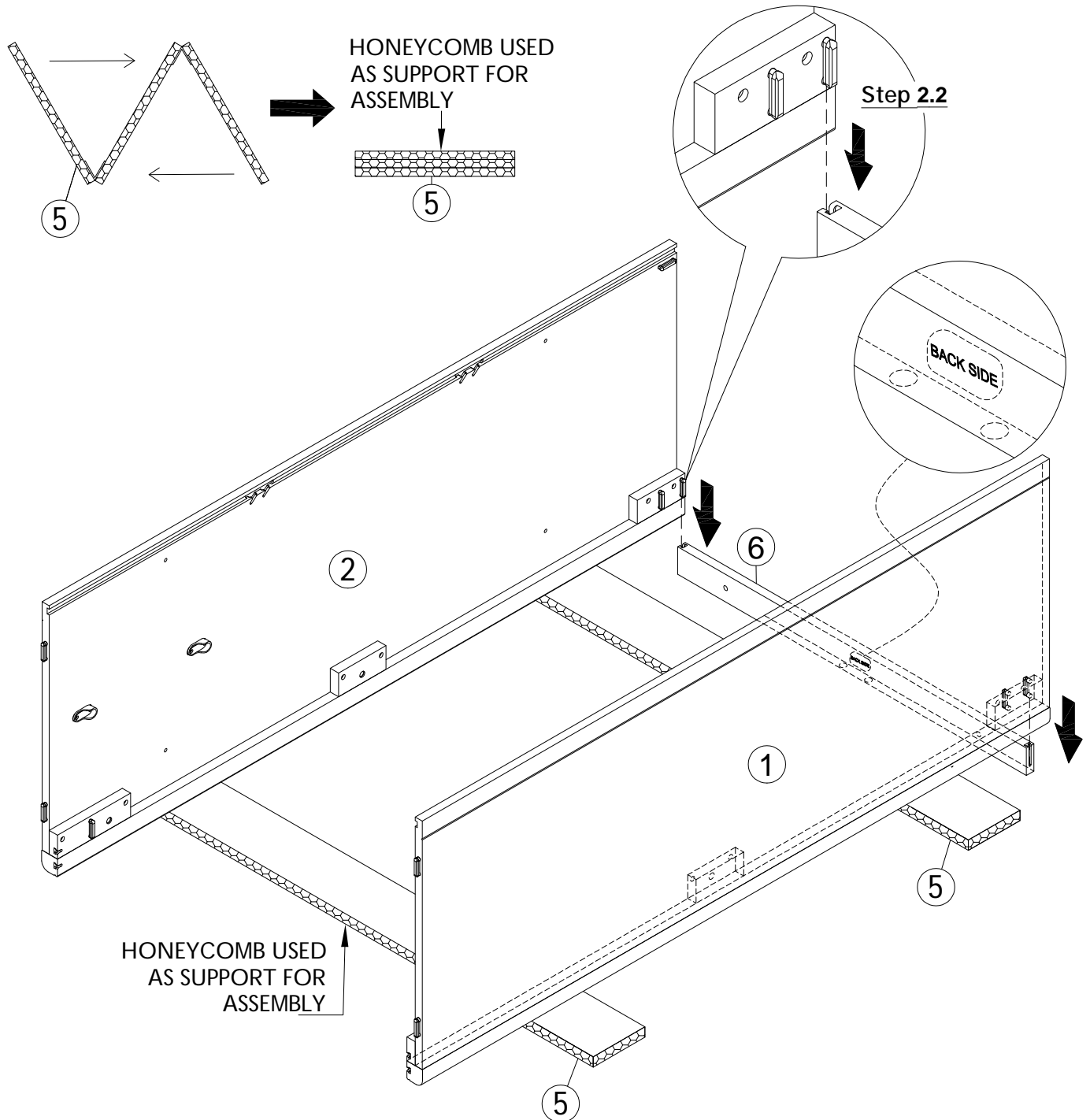

Step by step assembly instructions

Step 3 Attach bottom back rail (7) into side frames (1) & (2) by inserting dowels into the corresponding slots on the bottom back rail (7) as shown.

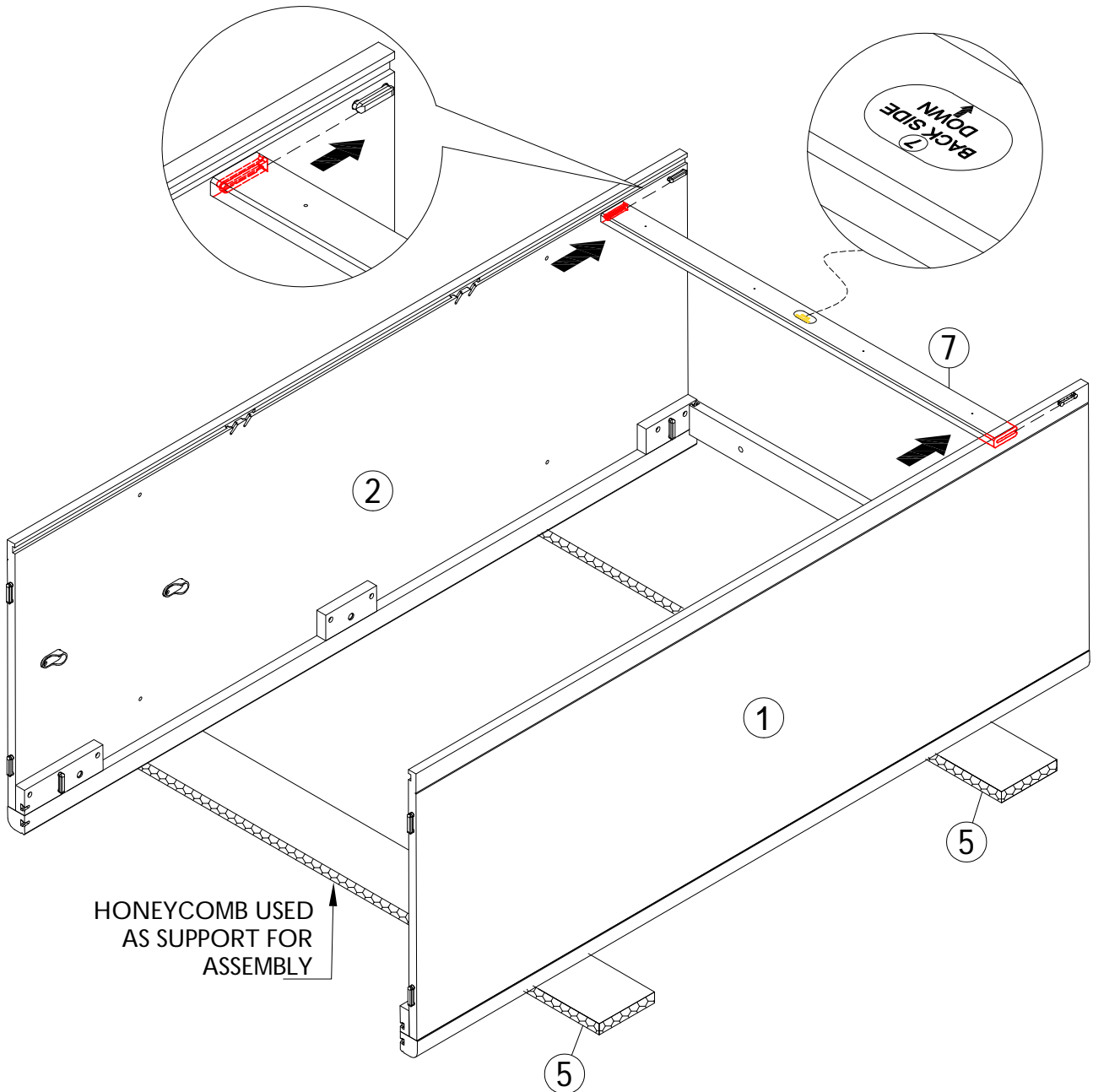

Step by step assembly instructions

- Step 4** 4.1 : Push out side frames (1) & (2) slightly to insert middle back rails. Attach 2x middle back rails (8) into side frames (1) & (2) by inserting dowels into the corresponding slots on the side frames (1) & (2) as shown.
- 4.2 : Attach top front rail (3) into side frames (1) & (2) by inserting dowels into the corresponding slots on the side frames (1) & (2) as shown.
- Push the middle back rails (8), top front rail (3) to "lock dowels slide pin" in place.

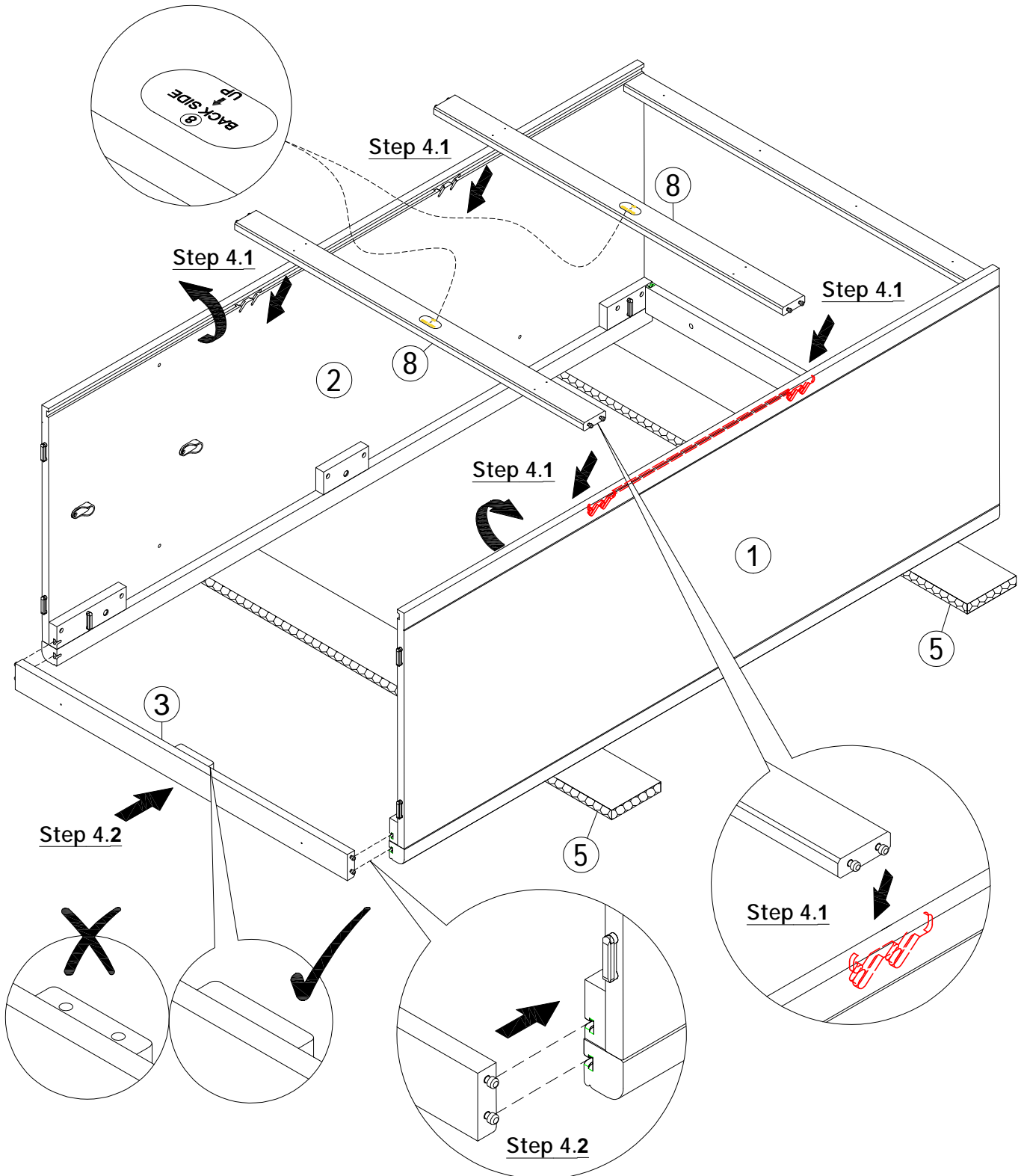

Step by step assembly instructions

Step 5 Attach top frame (9) into side frames (1) & (2) by inserting dowels into the corresponding slots on the top frame (9). Push the top frame (9) downward to lock the dowels in place, as shown.

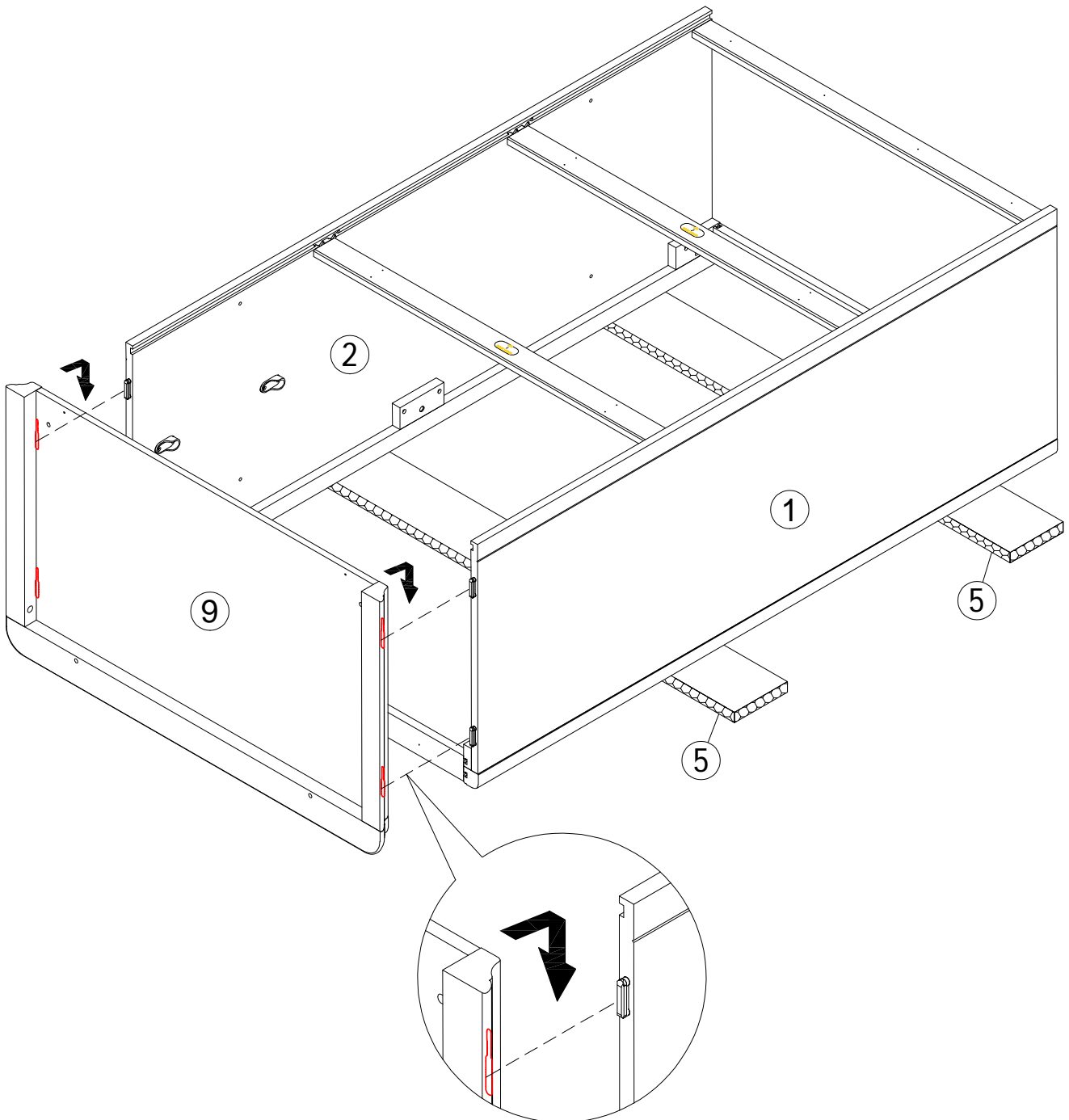

Step by step assembly instructions

- Step 6** 6.1 : Attach 1x back panel A (10) onto the structure assembled in Step 5 as shown. Ensure back panel A (10) is inserted into the groove in the side frames and spring pins is inserted correctly into the drilled holes.
- 6.2 : Continue, attach 1x back panel A (10) and back panel B (11) onto the structure assembled in Step 5 as shown. Ensure the back panels are inserted into the groove in the side frames and spring pins are inserted correctly into the drilled holes.
- Note :** Make sure there is no gap between back panels when pushing the panels in.

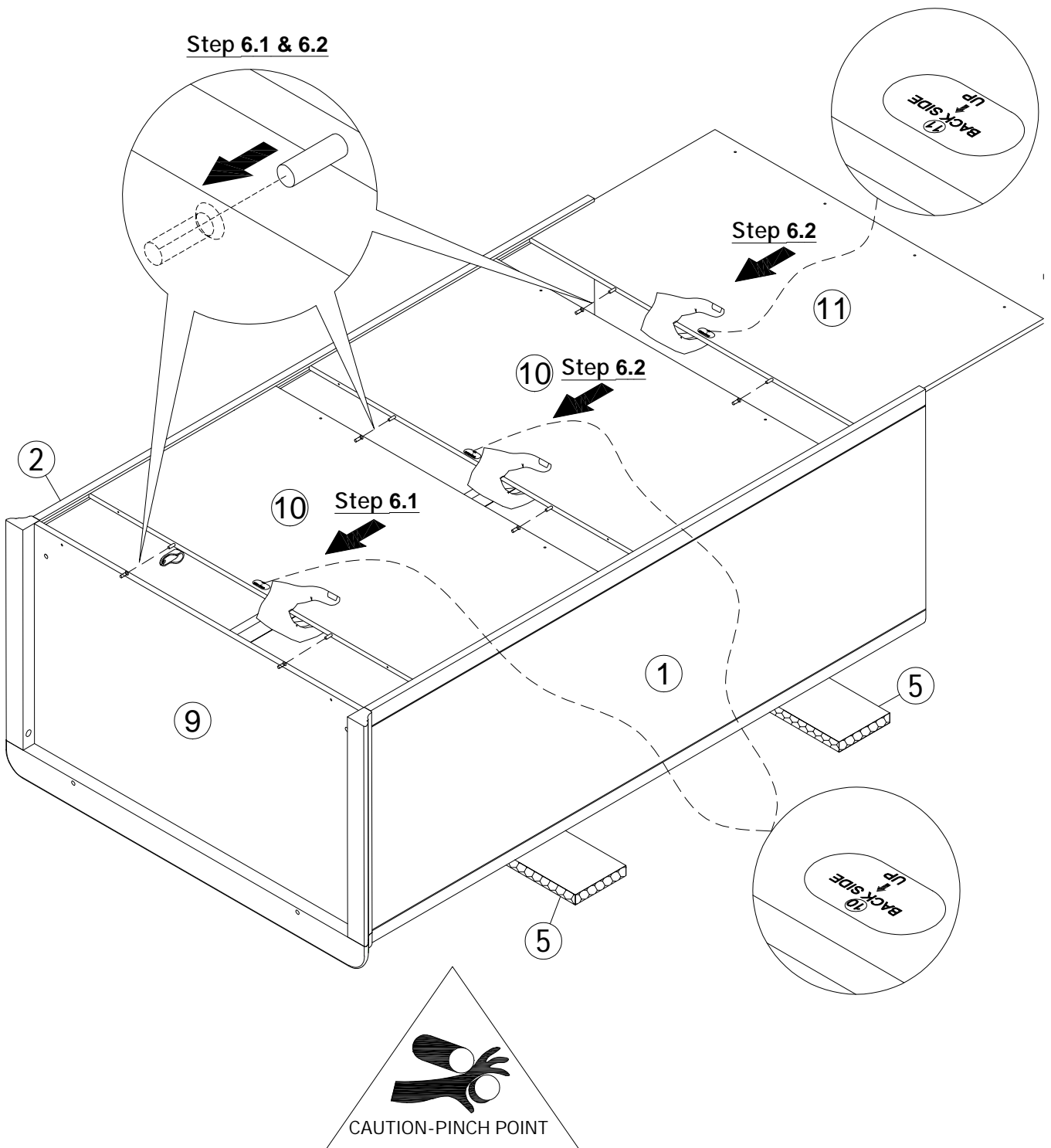

Step by step assembly instructions

- Step 7**
- 7.1 : Secure top frame (9) to 1x part (10) and part (3) using 2x Hi-Lo screws (B) and 2x round head screws (C) as shown. Use a pozi screwdriver to turn fittings (B), (C) clockwise fix.
 - 7.2 : Secure parts (10) to parts (8) using 4x round head screws (C) as shown. Use a pozi screwdriver to turn fittings (C) clockwise fix.
 - 7.3 : Secure part (11) to part (7) using 4x round head screws (C) as shown. Use a pozi screwdriver to turn fittings (C) clockwise fix.
 - 7.4 : Remove the plastic from 4x felts (D) and stick felts (D) onto under of part (12) as shown.
 - 7.5 : Stand the unit and double wardrobe base upright.

Fitting

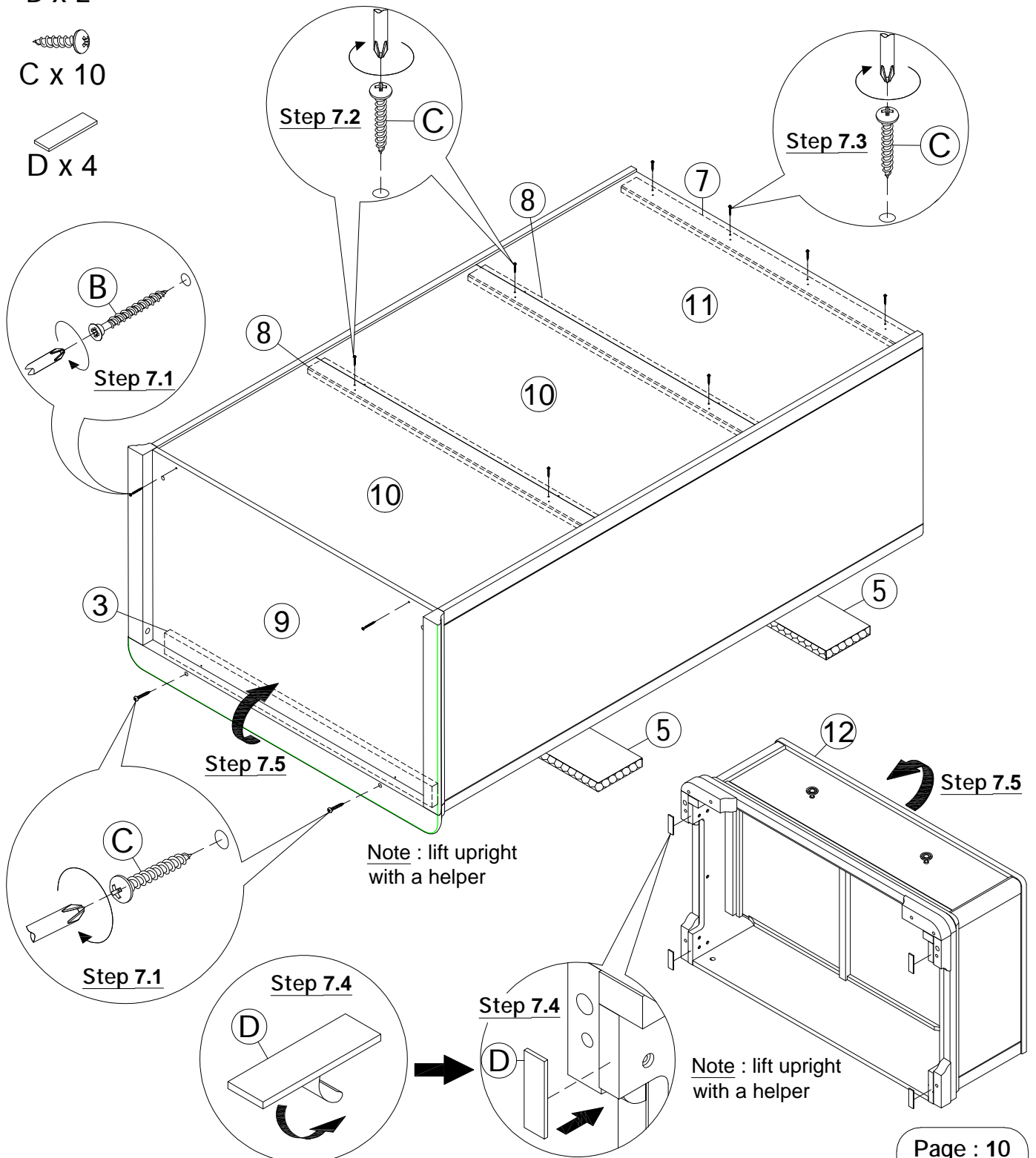
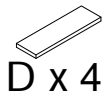
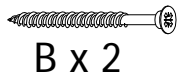

Step by step assembly instructions

- Step 8** **Note :** This product is heavy, it should be assembled as near as possible to the point of use.
: With help of assistant, carefully lift the double wardrobe top upwards over the double wardrobe base (12).
: Carefully lower double wardrobe top onto double wardrobe base (12). Ensure the holes under double wardrobe top are aligned correctly with the mating spring pins on double wardrobe base (12) to avoid damage as shown.

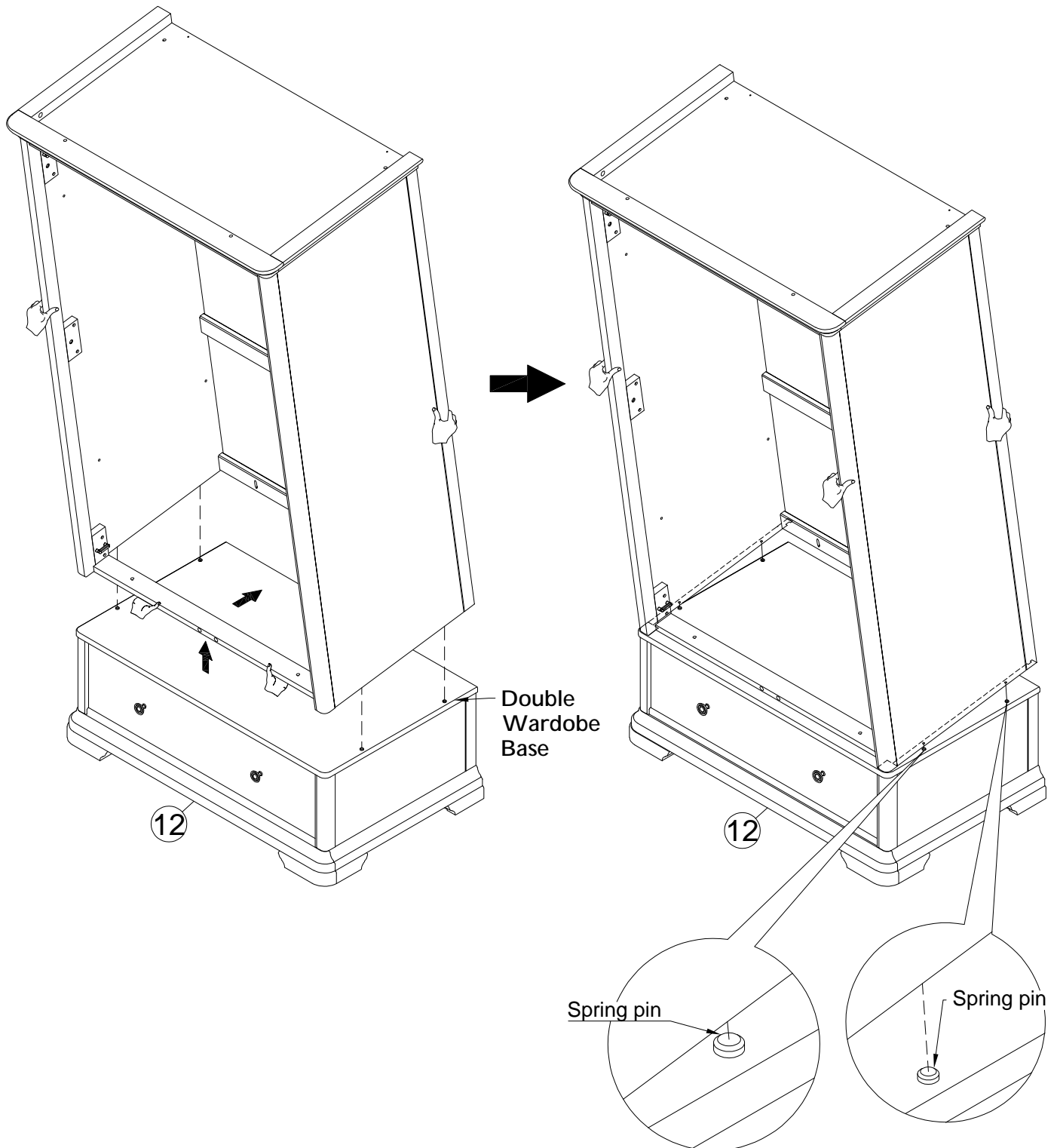

Step by step assembly instructions

Step 9 Secure double wardrobe top to double wardrobe base by screwing 4x round head screws (C) into the pre-drilled holes on bottom front rail (6) and bottom back rail (7) as shown. Use a pozi screwdriver to turn fittings (C) clockwise to fix.

Fitting



C x 4

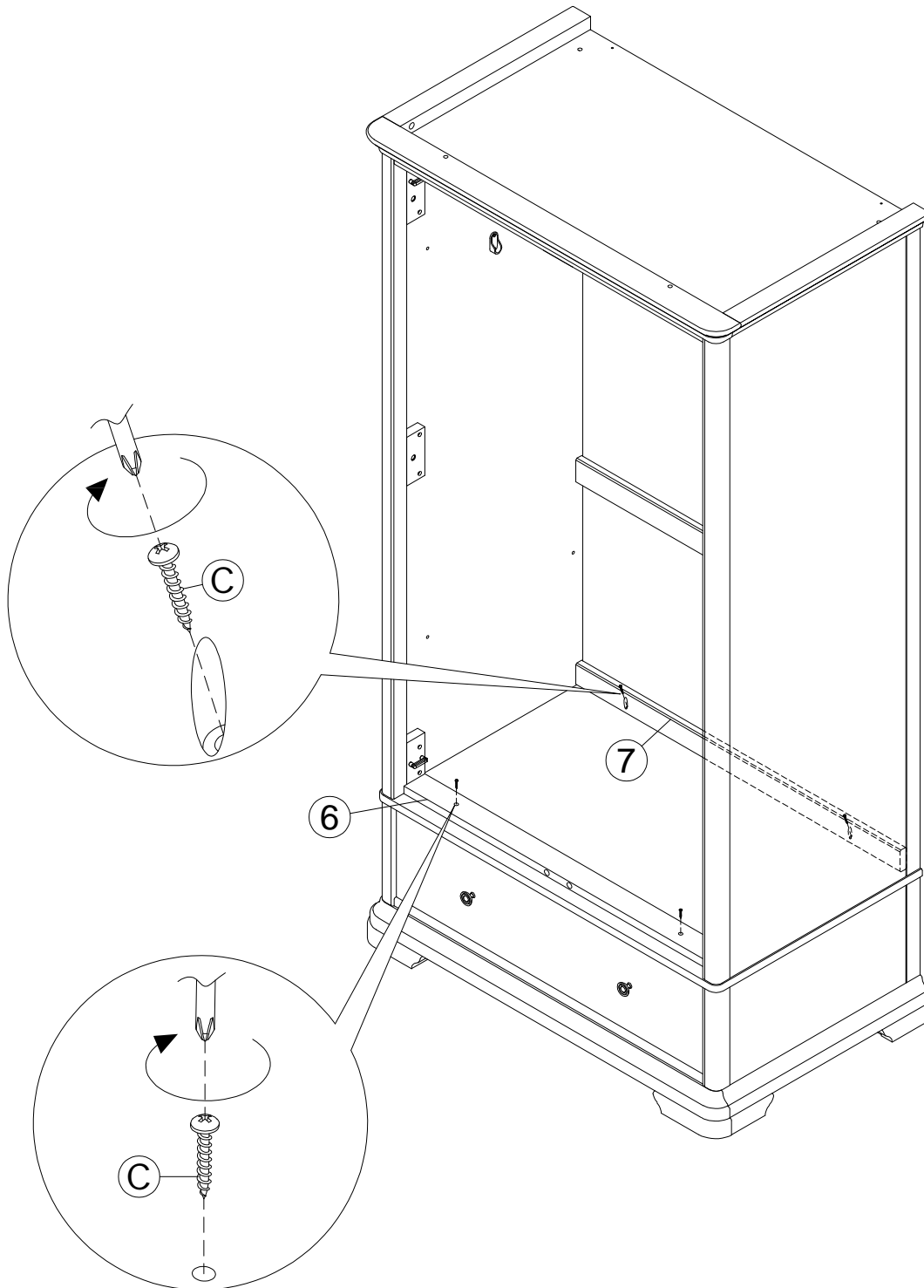

Step by step assembly instructions

Step 10 10.1 : Attach doors (13) & (14) to side frames (1) & (2) by inserting dowels into the corresponding slots on doors (13) & (14) as shown. Ensure dowels are locked in place.

10.2 : Secure doors (13) and (14) to sides frames (1) and (2) using 4x hex head bolts (E) into the recessed fittings located on parts (1) and (2) as shown.

Make sure the holes on the doors are properly aligned with the holes on the side frames (1) & (2) before attaching. Use allen key (F) to turn the fittings (E) clockwise to fix.

10.3 : Attach 2x handles (G) to the front of doors (13) & (14) using 2x round head bolts (H) as shown. Use a phillips screwdriver to turn fittings (H) clockwise to fix.

Fitting



E x 4



F x 1



G x 2



H x 2

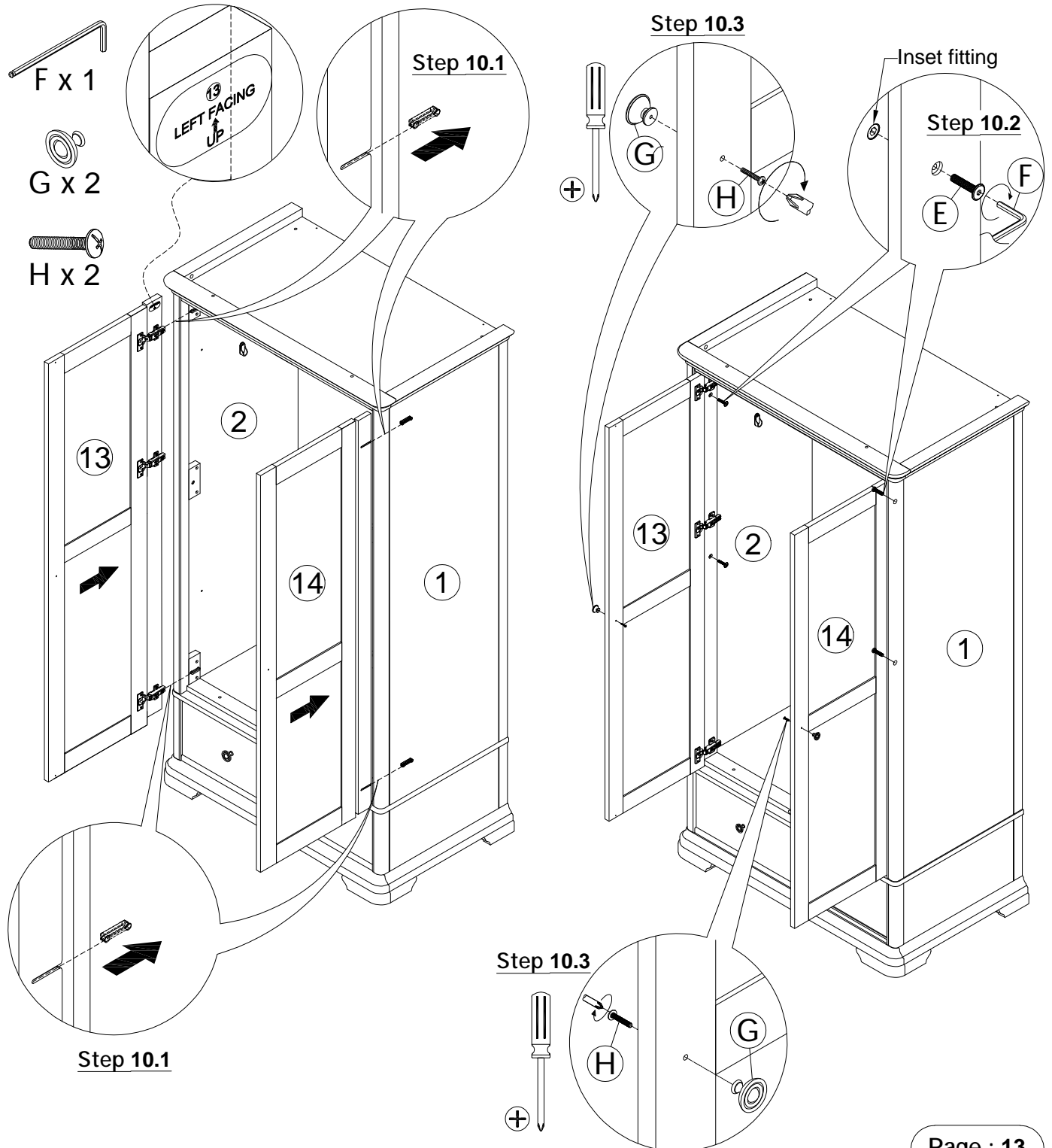

Step by step assembly instructions

Step 11 11.1 : Place clothes rail bar (J) onto hanger rail supports (A) on left & right side frames of unit as shown.

Note : clothes rail bar (J) can be installed in both up and down of the unit.

11.2 : Screw 2x shelf pins (K) into the insert fittings in left side frame (2) as shown.

11.3 : Tilt removable shelf frame (15) to a suitable angle as shown in the picture so as to slide it in.

11.4 : Slide removable shelf frame (15) into the unit. Ensure the holes on removable shelf frame (15) are facing down, then lower the left side of part (15) onto the pins of shelf pins (K) as shown.

Fitting



K x 2



J x 1

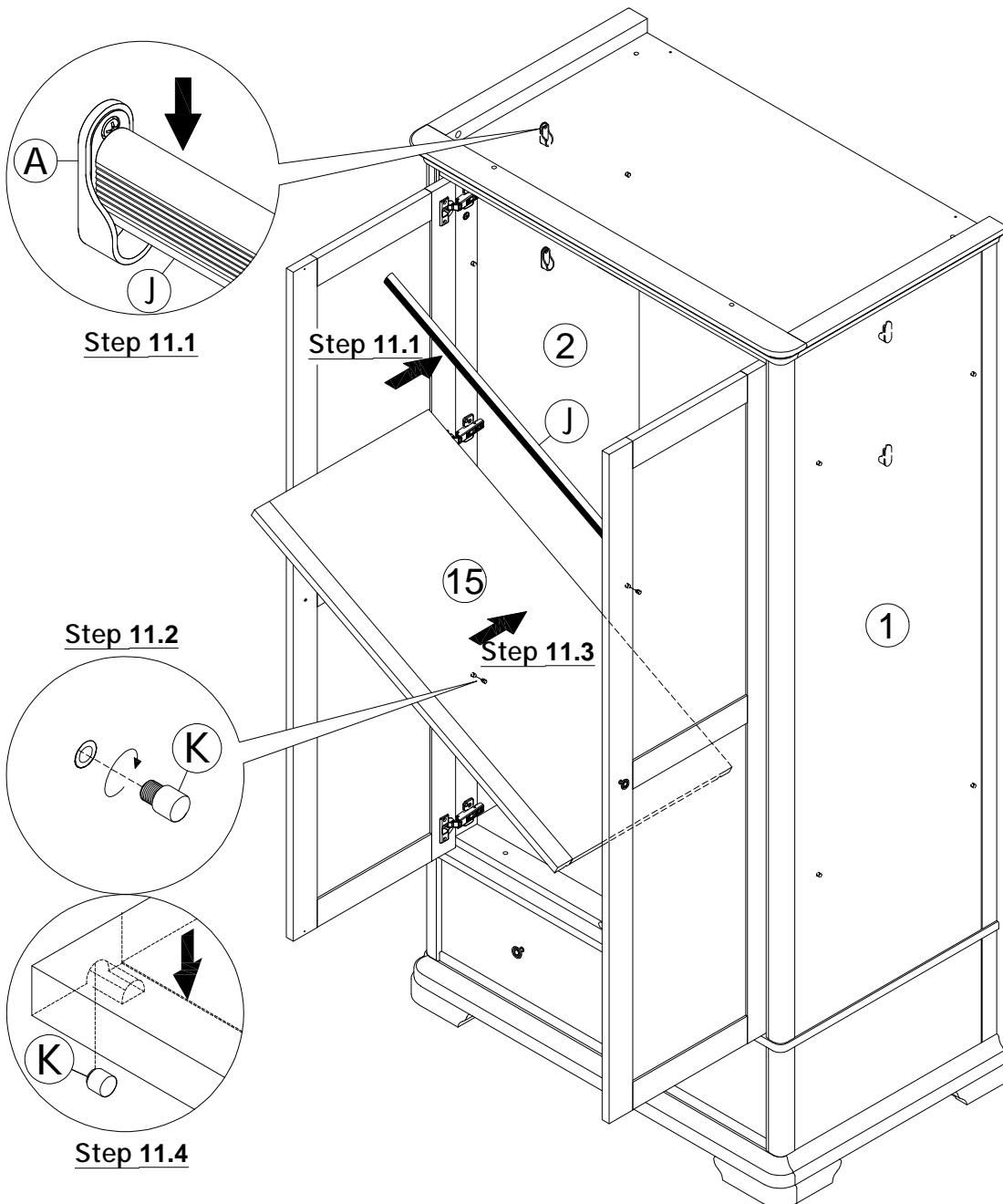

Step by step assembly instructions

Step 11 **Continue:**

11.5 : Lift up right side of removable shelf frame (15).

11.6 : Screw 2x shelf pins (K) into the insert fittings in right side frame (1) as shown.

11.7 : Lower removable shelf frame (15) onto the pins of shelf pins (K) as shown.

Fitting



K x 2

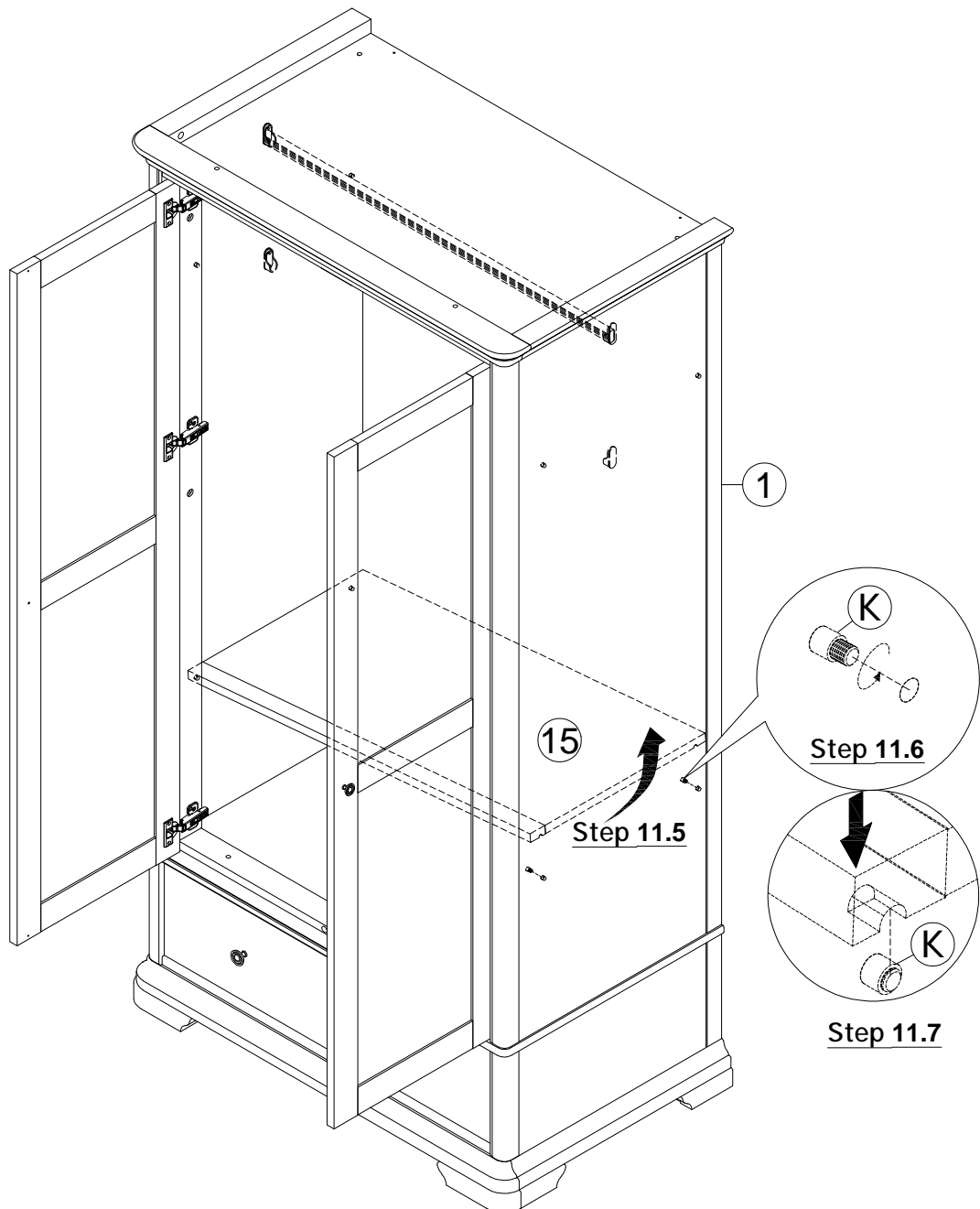

Step by step assembly instructions

Step 12 Note : The clothes rail (J) and removable shelf frame (15) can be installed into the wardrobe in 2 ways as shown.

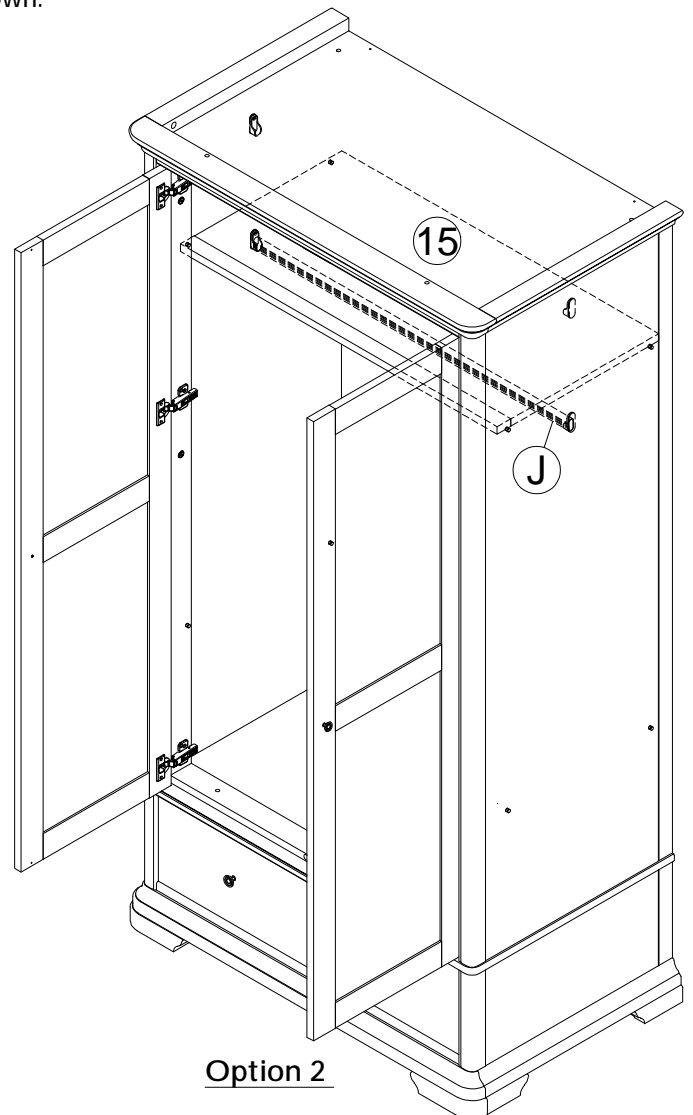
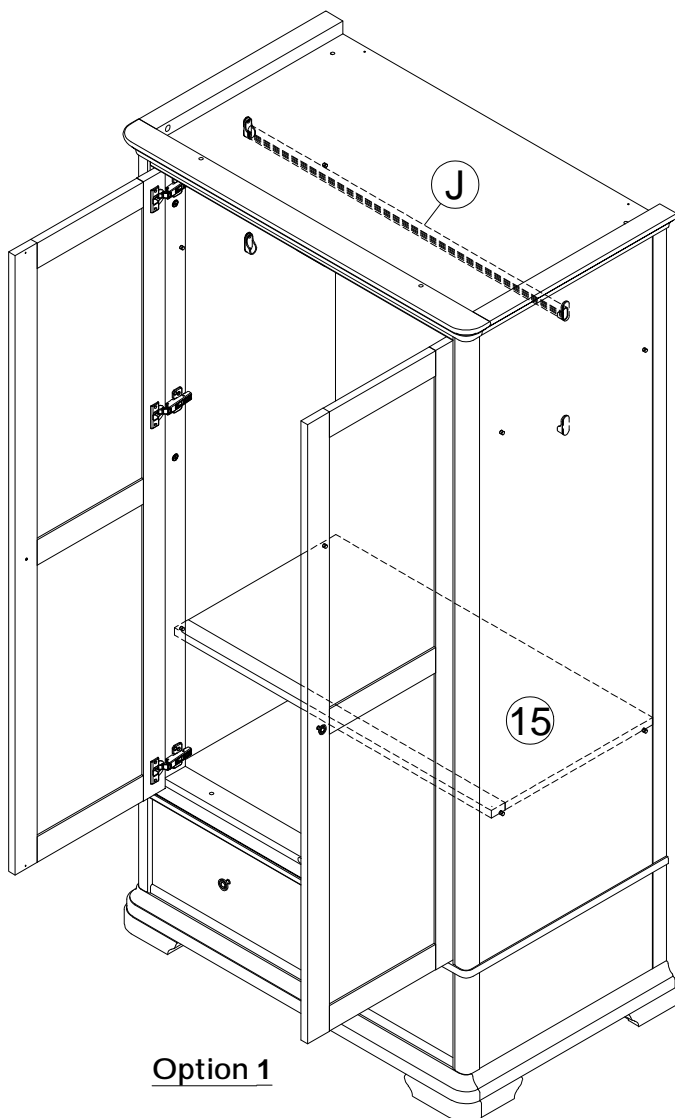

Step by step assembly instructions

Step 13 If cabinet not level, please insert 2x plastic leveler (L) under legs as required to level and square the cabinet.

13.1 : Push 2x plastic leveler (L) in as far as you need to level the furniture.

13.2 :Then snap off the excess.

Fitting



L x 2

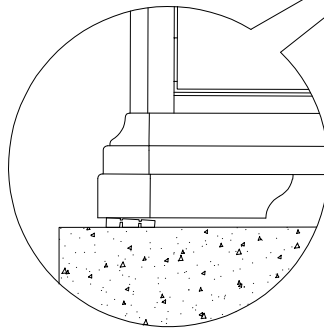
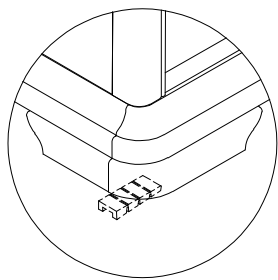
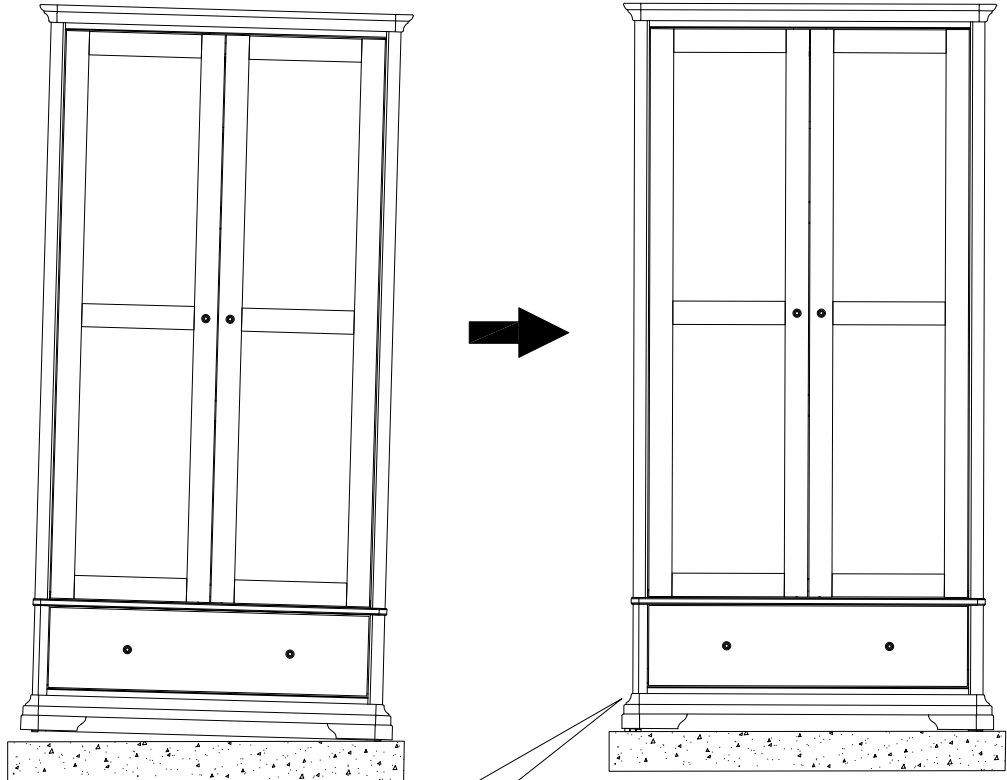

Step 13.1

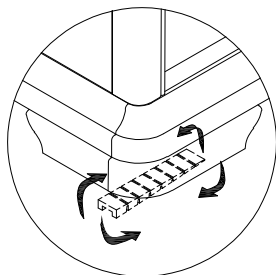

Step 13.2

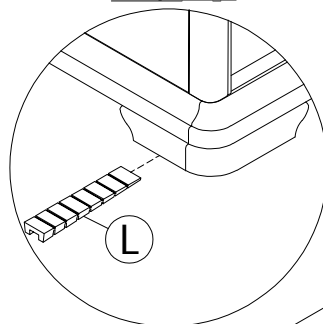

Lift one leg left or right as applicable and insert the wedge

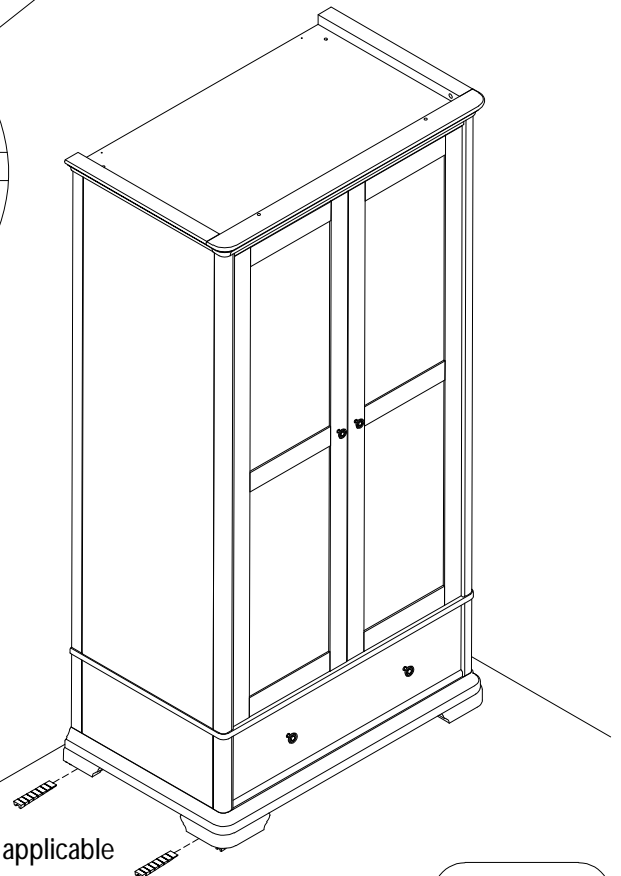

UNDERMOUNT DRAWER GLIDE ADJUSTMENT INSTRUCTION

ASSEMBLE

Lay the drawer bottom onto the slide then push the drawer into the cabinet

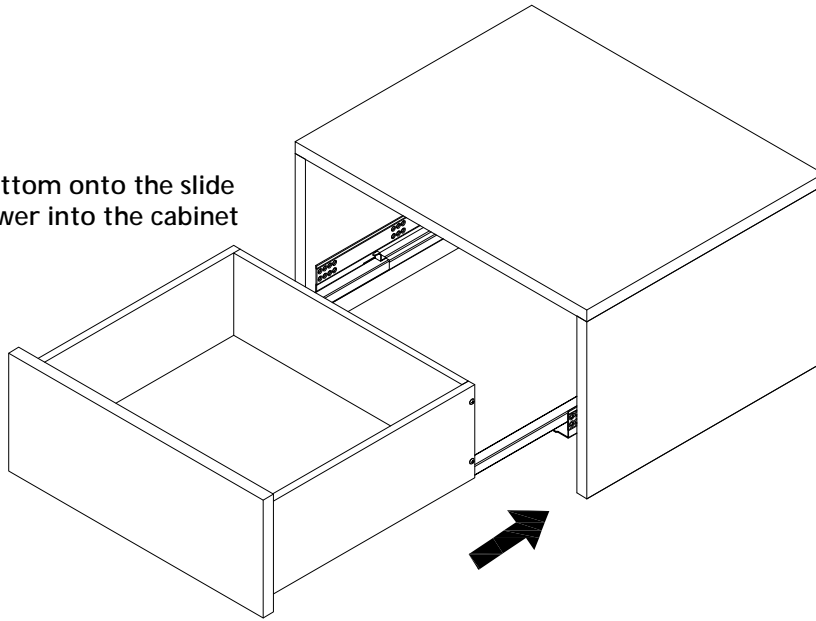

HEIGHT ADJUSTMENT

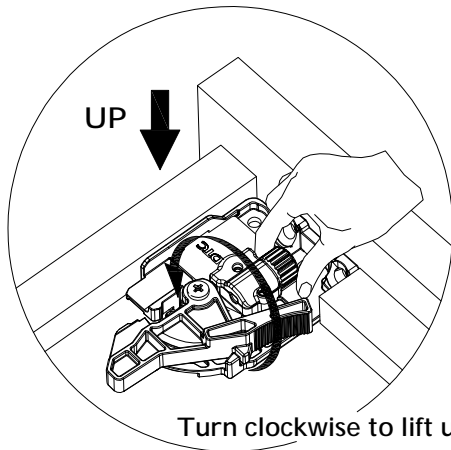

Turn clockwise to lift up

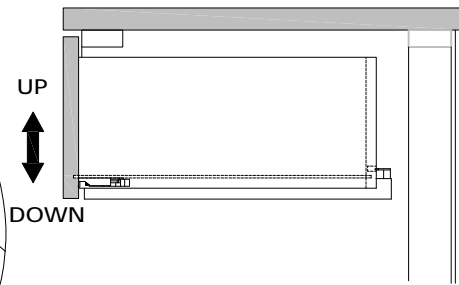

Turn counterclockwise to down

REMOVE

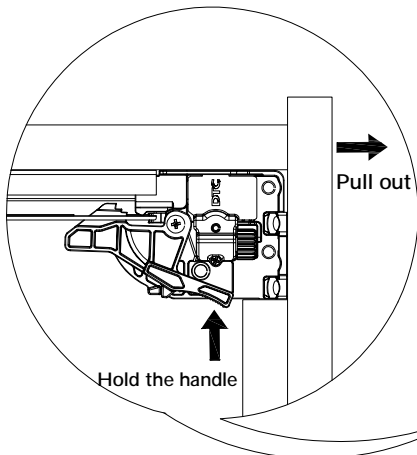

Hold the handle

Pull out

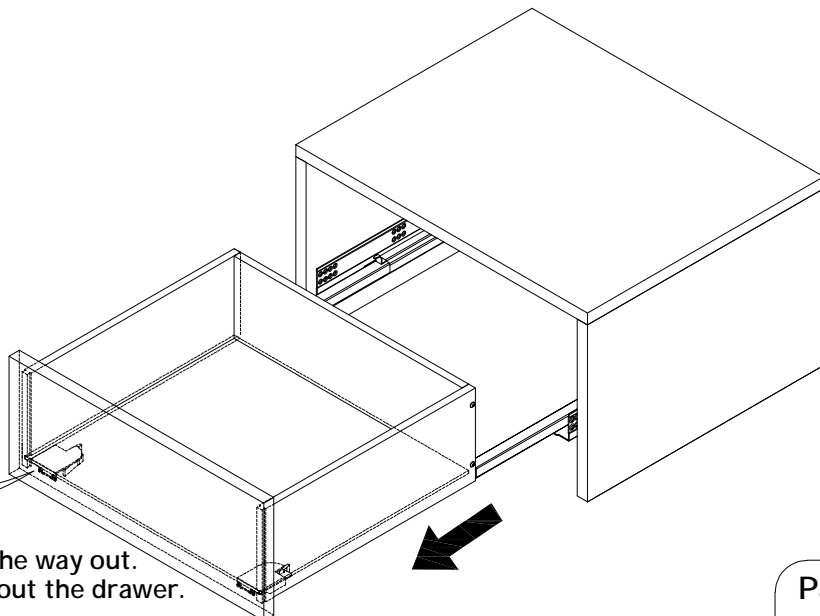

For removal, extend the runner all the way out. Unlock by hold the handle and pull out the drawer.

HINGE ADJUSTMENT INSTRUCTIONS

LATERAL ADJUSTMENT
by screw adjustment.

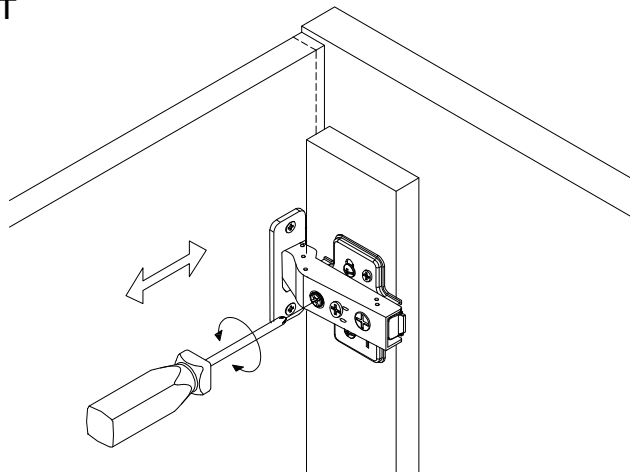

FRONT-TO-BACK
by slackening and retightening
the hinge-arm mounting screw.

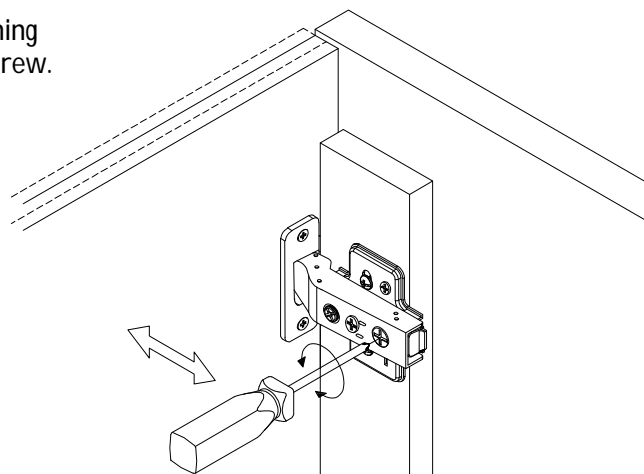

VERTICAL ADJUSTMENT
via slots on mounting plate by
slackening and retightening the
screws on mounting plate

1.1

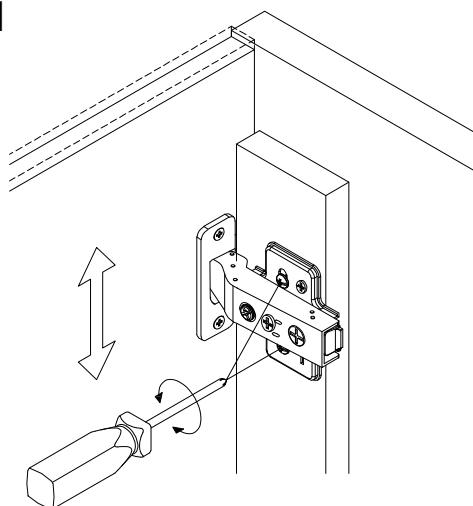

1.2

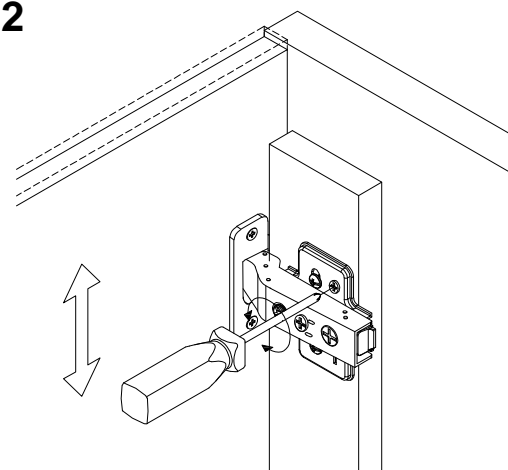

HINGE ADJUSTMENT INSTRUCTIONS

SLOW DOWN CLOSING
by screw adjustment to clockwise.

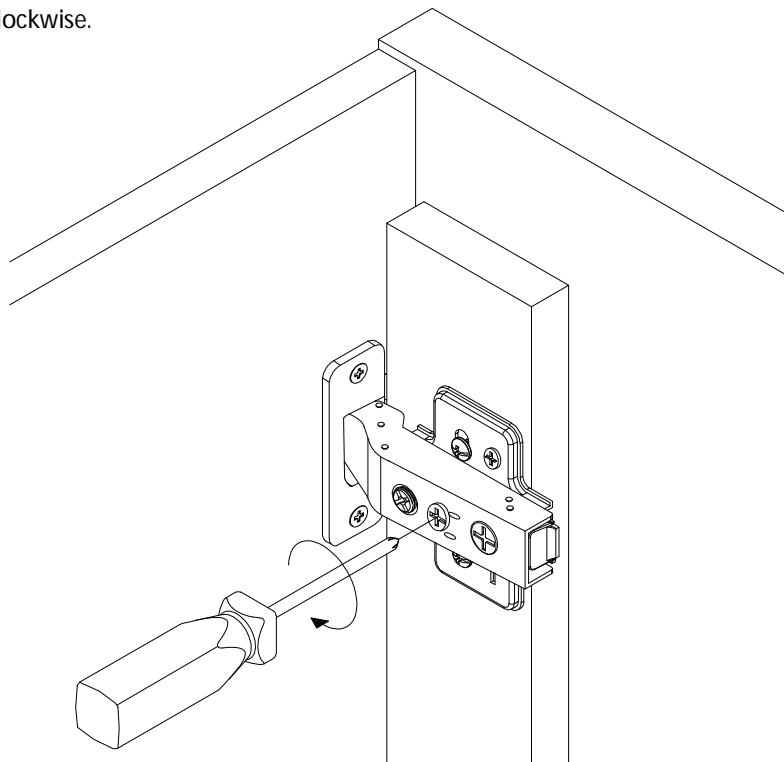

SPEED UP CLOSING
by screw adjustment to counter clockwise.

