

CONSOLE TABLE

Stock number: 280X-19

Thank you for purchasing this product. Please read the instructions carefully before use to ensure safe and satisfactory operation of this product.

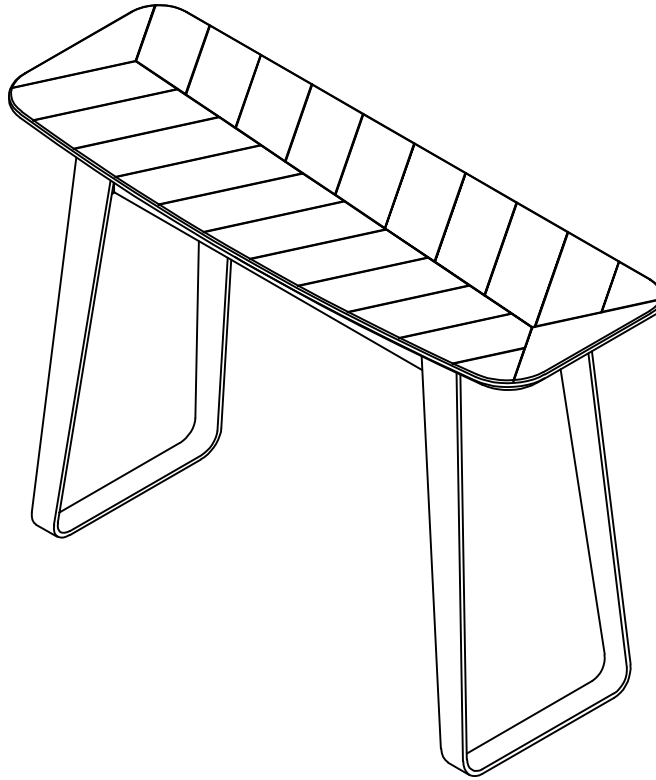

Pre-assembly preparation

Please ensure instructions are read in full before attempting to assemble this product.

Necessary Tools:

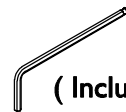
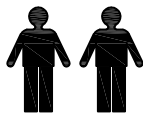

(Included)

Please check the pack contents before attempting to assemble this product. A full checklist of components is given in this leaflet, if any components are missing, please contact the retailer from whom you bought this product.

This product takes approximately **20 MINUTES** to assemble with **2 PEOPLE**.

All assembly should be performed on a flat, stable, clean and soft surface.

This product is **HEAVY**, it should be assembled as near as possible to the point of use. **TAKE CARE WHEN LIFTING** to avoid personal injury and (or) damage to the product.

The fitting pack contains **SMALL ITEMS** which should be **KEPT AWAY FROM YOUNG CHILDREN**.





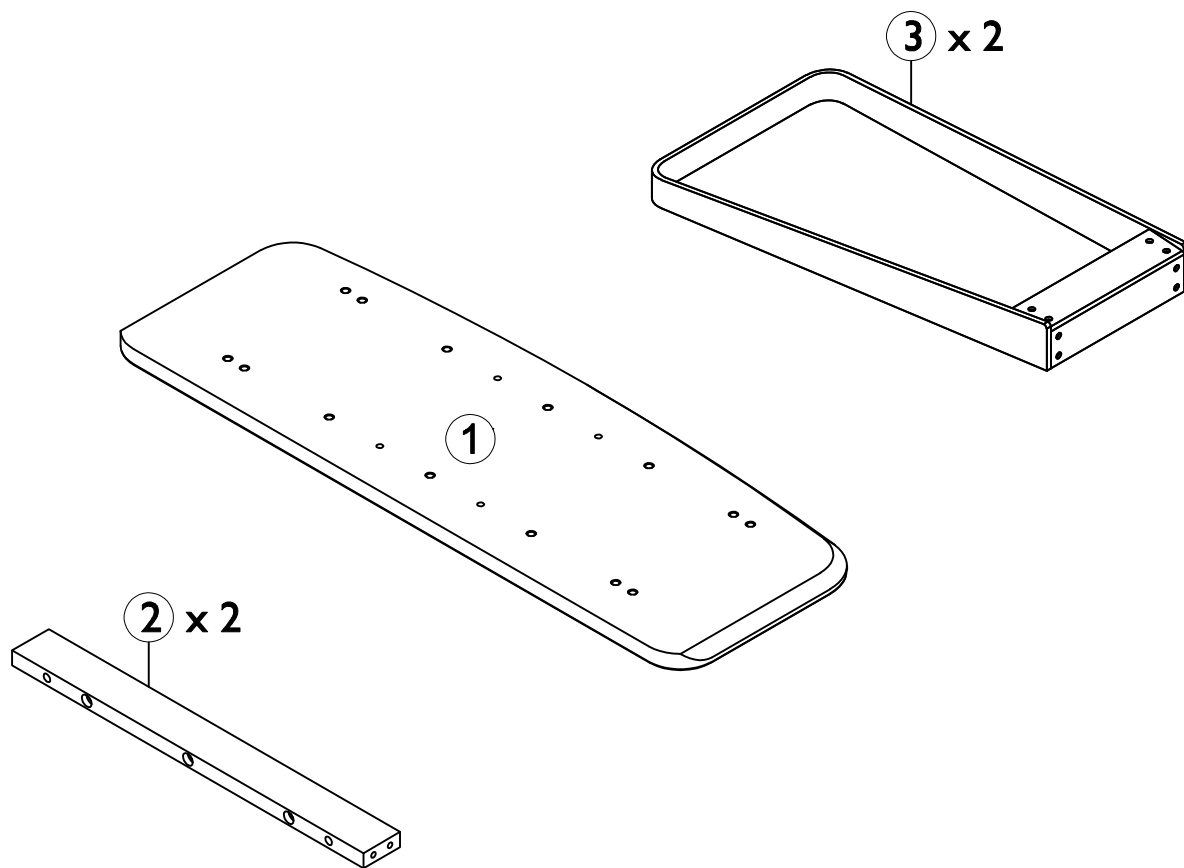

IMPORTANT: Retain these instructions for future reference.

Page : 1

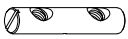
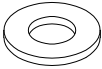
IW-17-280X-06-0-R1

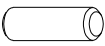

Fittings and parts checklist

Item	Description	Qty.	Item	Description	Qty.
1	Top Panel	x 1	3	Metal leg	x 2
2	Side Apron	x 2			
A	Cross dowel Ø12x60mm	 x 4	E	Flat washer Ø8.4xØ17x1.6mm	 x 6
B	Short hex head bolt M8x20mm	 x 8	F	Allen key M4x30x110mm	 x 1
C	Long hex head bolt M8x80mm	 x 14	J	Wooden dowel Ø10x30mm	 x 4
D	Lock washer Ø8.4x2mm	 x 6			

Step By Step Assembly Instructions

Step 1

- 1.1 : Lay all parts on a flat, stable, clean and soft surface.
- 1.2 : Insert 4x wooden dowels (J) into the pre-drilled holes on side apron (2) as shown.
- 1.3 : Attach side aprons (2) onto top panel (1) as shown. Ensure wooden dowels (J) are aligned correctly with the holes of mating parts before attaching.
- 1.4 : Attach 6x long hex head bolt (C), lock washer (D) and washer (E) into top panel (1) by placing each fitting (C) into the holes on top of each side aprons (2) use an allen key (F) to turn fittings (C) clockwise to fix.
- 1.5 : Insert 4x cross dowels (A) into side aprons (2) by placing each fitting (A) into the holes on top of each side apron. Ensure the horizontal marking on each fitting is facing as shown.

Fitting



A x 4



C x 6



D x 6



E x 6



F x 1



J x 4

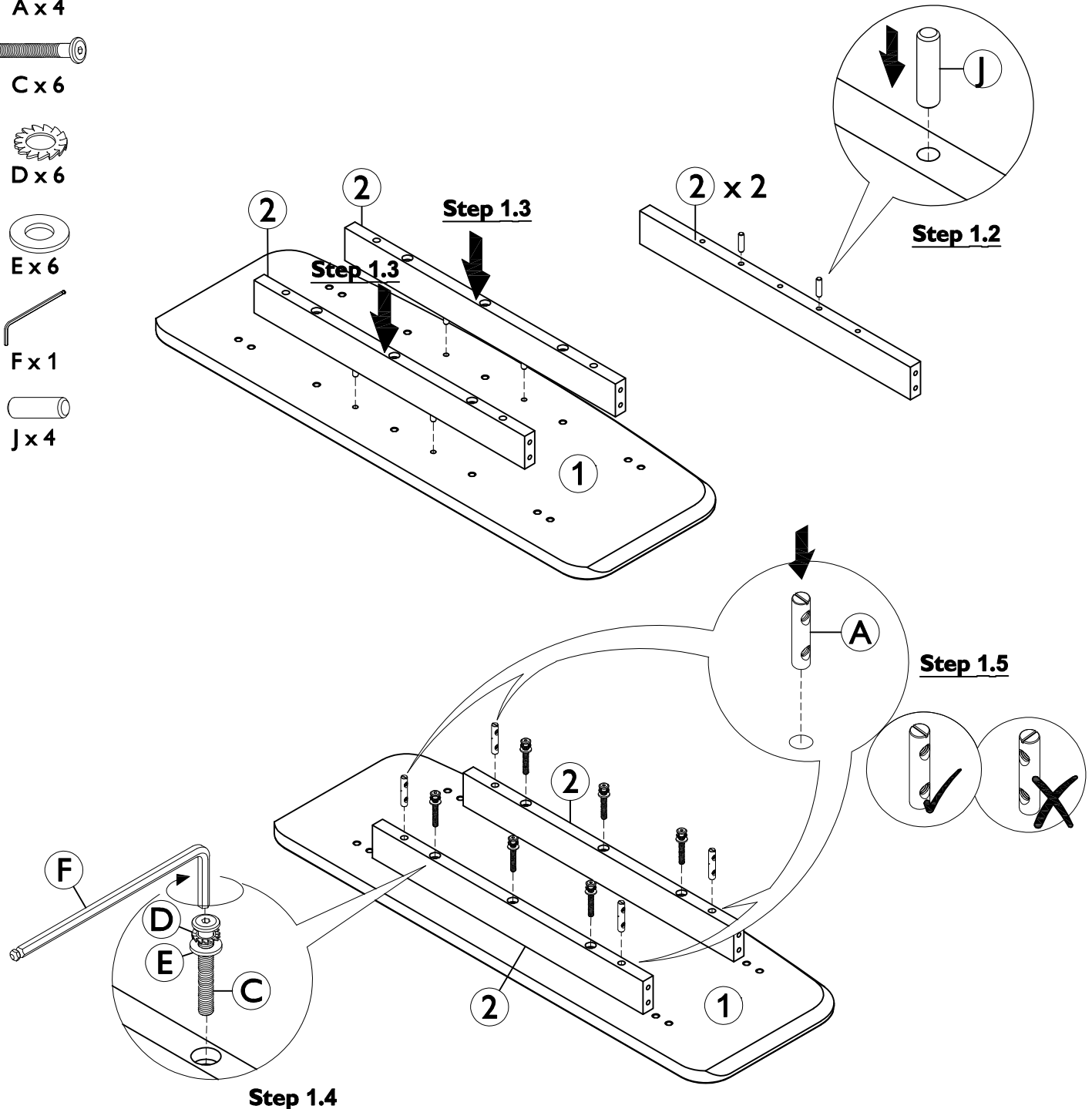

Step By Step Assembly Instructions

- Step 2** 2.1 : Place metal legs (3) onto side aprons (2). Ensure the pre-drilled holes on metal leg (3) are aligned correctly with the pre-drilled holes on side apron (2) before attaching.
- 2.2 : Secure metal legs (3) to side aprons (2) by screwing 8x long hex head bolts (C) into the cross dowels (A) are located on side apron (2) as shown. Use an allen key (F) to turn bolts clockwise to fix. **Do not fully tightening.**

Fitting

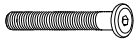

C x 8

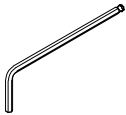

F x 1

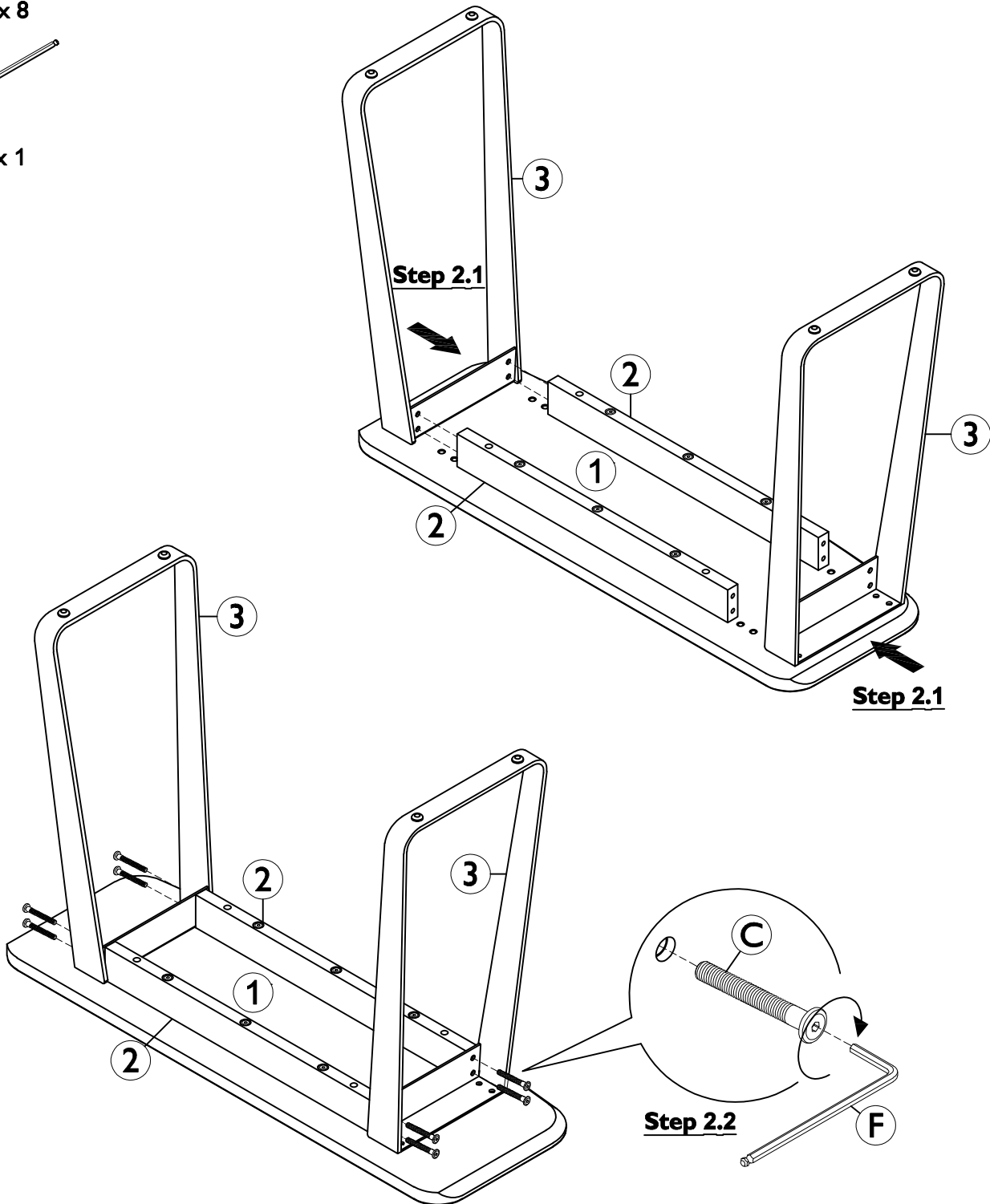

Step By Step Assembly Instructions

Step 3 3.1 : Secure metal legs (3) to top panel (1) by screwing 8x short hex head bolts (B) into the inset fitting that are located on top panel (1) as shown. Use an allen key (F) to turn bolts clockwise to fix.

3.2 : **Re-tightening**
3.3 : Stand the unit upright.

Fitting



B x 8

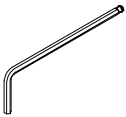

F x 1

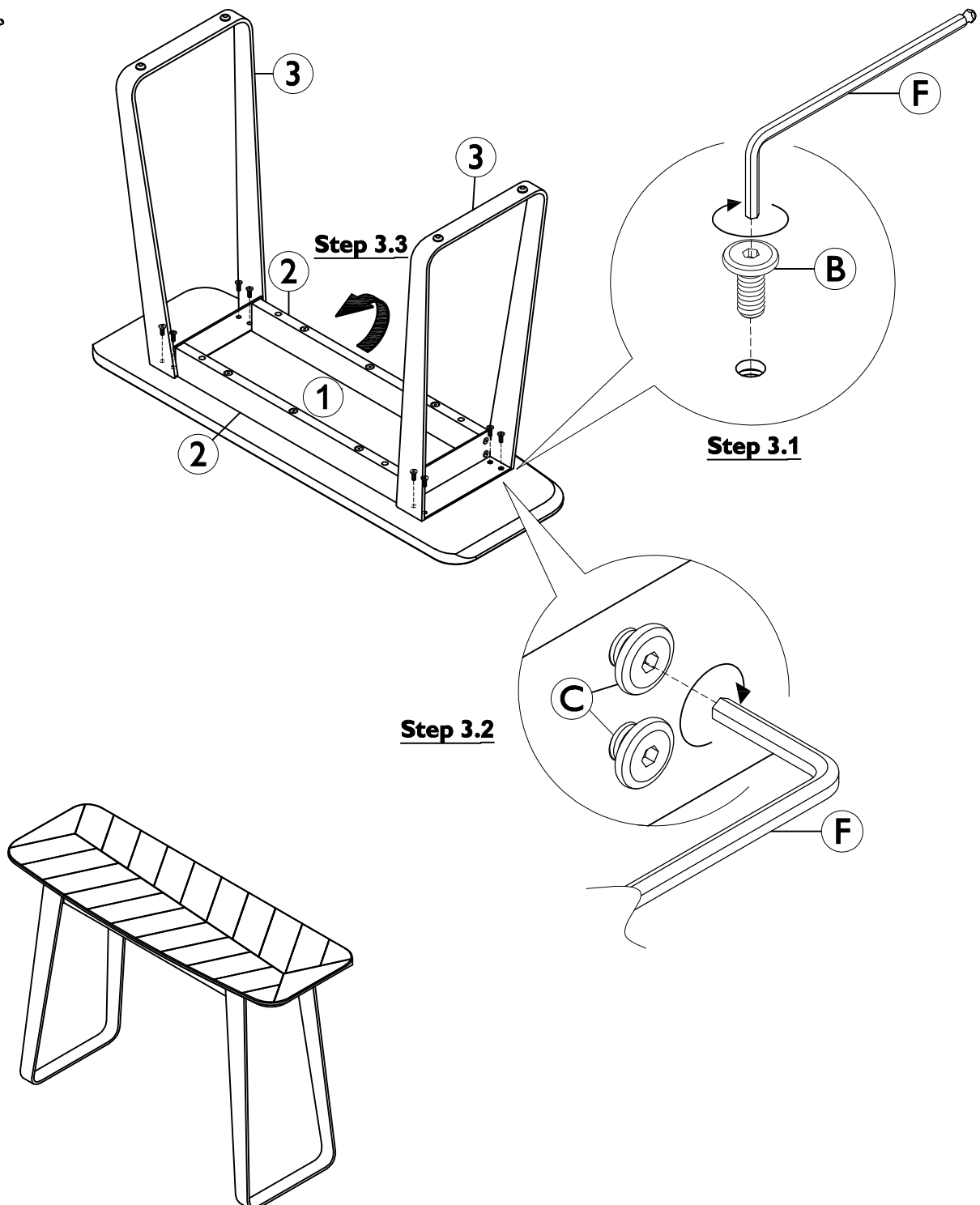

Assembly is complete