

# PROVENCE SLATTED CHAIR

Stock Number: 8871/8872-09S

Thank you for purchasing this Provence Slatted Chair. Please read the instructions carefully before use to ensure safe and satisfactory operation of this product.

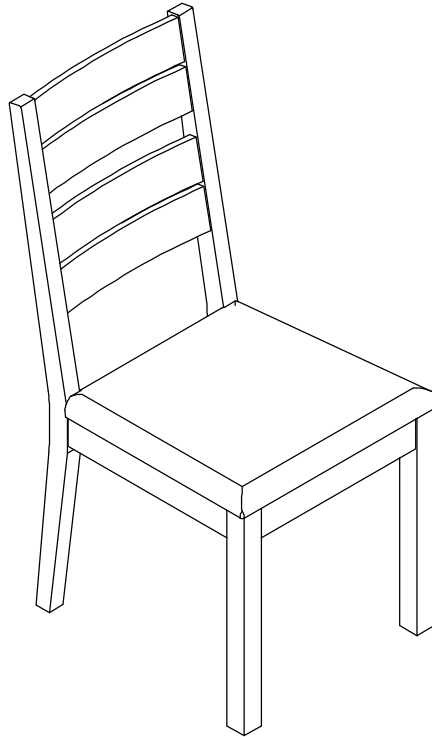

## Pre-assembly preparation

Please ensure instructions are read in full before attempting to assemble this product.

## Necessary Tools



( Included )

Please check the pack contents before attempting to assemble this product. A full checklist of components is given in this leaflet. If any components are missing, please contact the retailer from whom you bought this product.

This product takes approximately **5 MINUTES** to assemble with **1 PERSON**.

All assembly should be performed on a flat, stable, clean and soft surface.





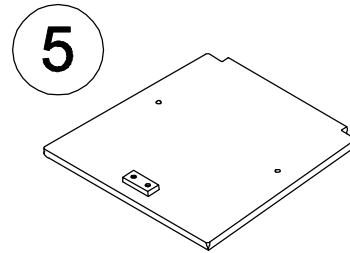
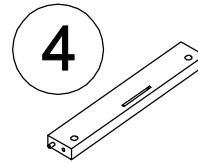
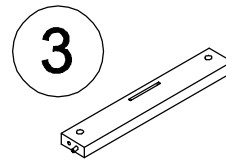
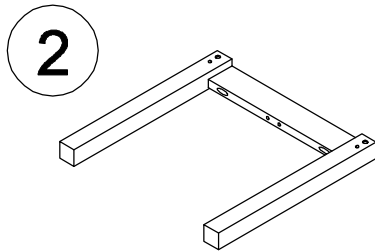
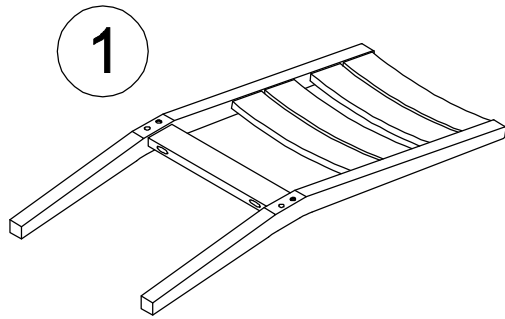

This product is **HEAVY**, it should be assembled as near as possible to the point of use. **TAKE CARE WHEN LIFTING** to avoid personal injury and (or) damage to the product

The fitting pack contains **SMALL ITEMS** which should be **KEPT AWAY FROM YOUNG CHILDREN**.

**IMPORTANT:** Retain these instructions for future reference.



## Fittings and parts checklist

Item	Description	Qty.	Item	Description	Qty.
1	Back leg frame	x 2	C	Hex key 5 x 100 	x 1
2	Front leg frame	x 2	D	Hex head bolt Ø6 x 12mm 	x 4
3	Apron - left	x 2	E	Seat bracket 	x 4
4	Apron - right	x 2	F	Hex key 4 x 110 	x 1
5	Seat pad	x 2			
A	Steel dowel Ø10 x 48.5  O-ring	x 8			
B	Grip Screw Ø6 x 8 	x 8			

# Step By Step Assembly Instructions

- Step 1**
- 1.1: Lay parts (1) and (2) on a flat, stable, clean and soft surface as shown.
  - 1.2: Insert 4x dowel (A) into the pre-drilled holes on back leg frame (1) and front leg frame (2). Ensure the holes on fitting (A) are facing the correct direction as per diagram.

Fitting

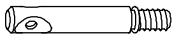

A x 4

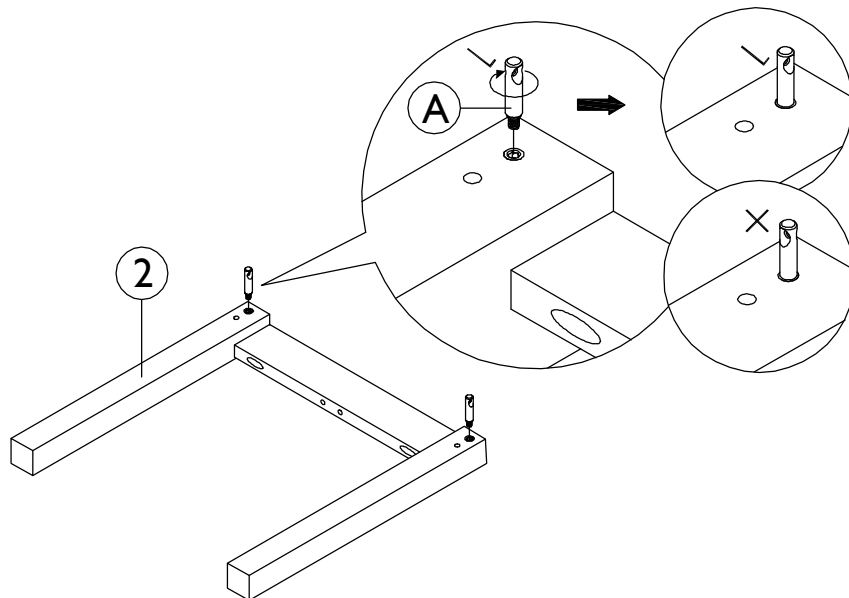
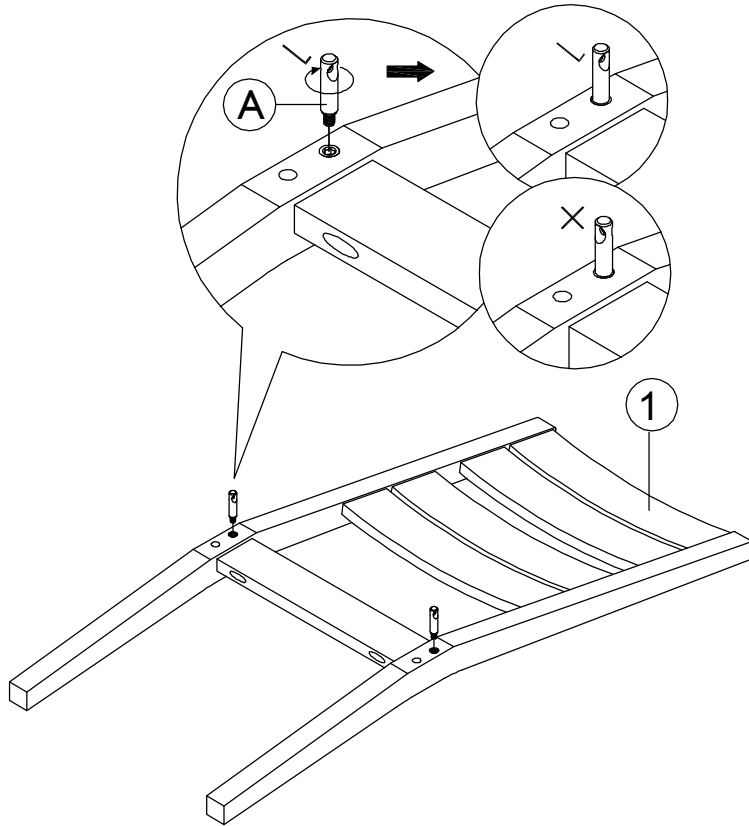

# Step By Step Assembly Instructions

**Step 2**: Attach apron - left (3) and apron - right (4) onto back leg frame (1) as shown. Ensure steel dowels (A) and small wooden dowels are aligned correctly with the mating holes to avoid damage. Secure both aprons to back leg frame (1) using 2 x grip screws (B) as shown. Use hex key (C) to turn fitting (B) clockwise to fix.

Fitting



B x 2



C x 1

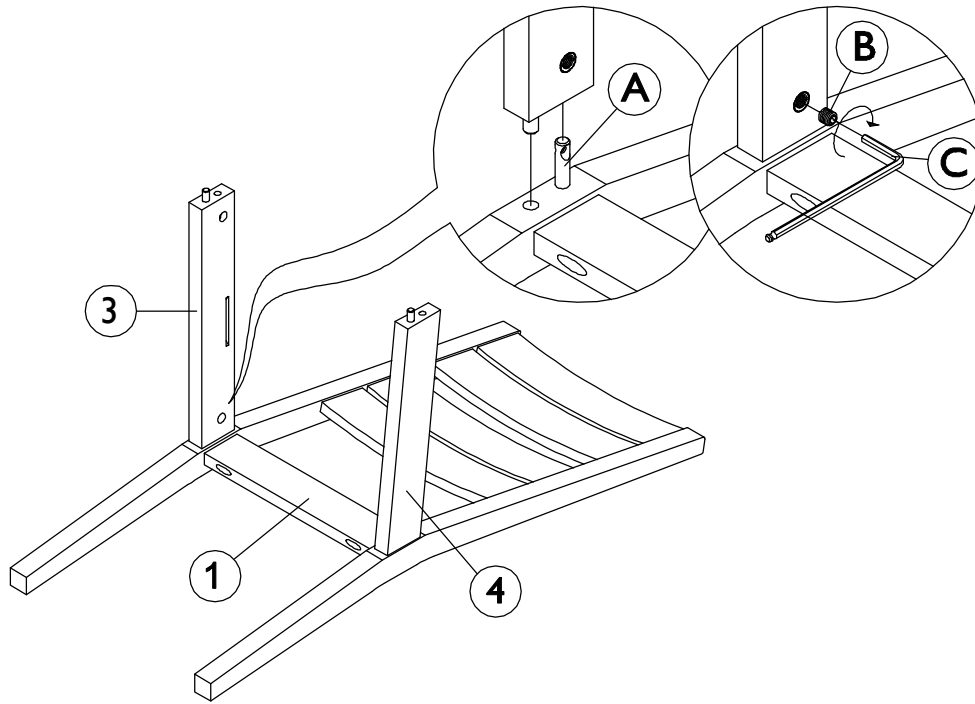

**Step 3**: Place front leg frame (2) onto top of aprons (3) and (4) as shown. Ensure steel dowels (A) and large wooden dowels are aligned correctly with the mating holes to avoid damage. Secure front leg frame (2) to both aprons (3) and (4) using 2 x grip screws (B) as shown. Use hexkey (C) to turn fitting (B) clockwise to fix.

Fitting



B x 2



C x 1

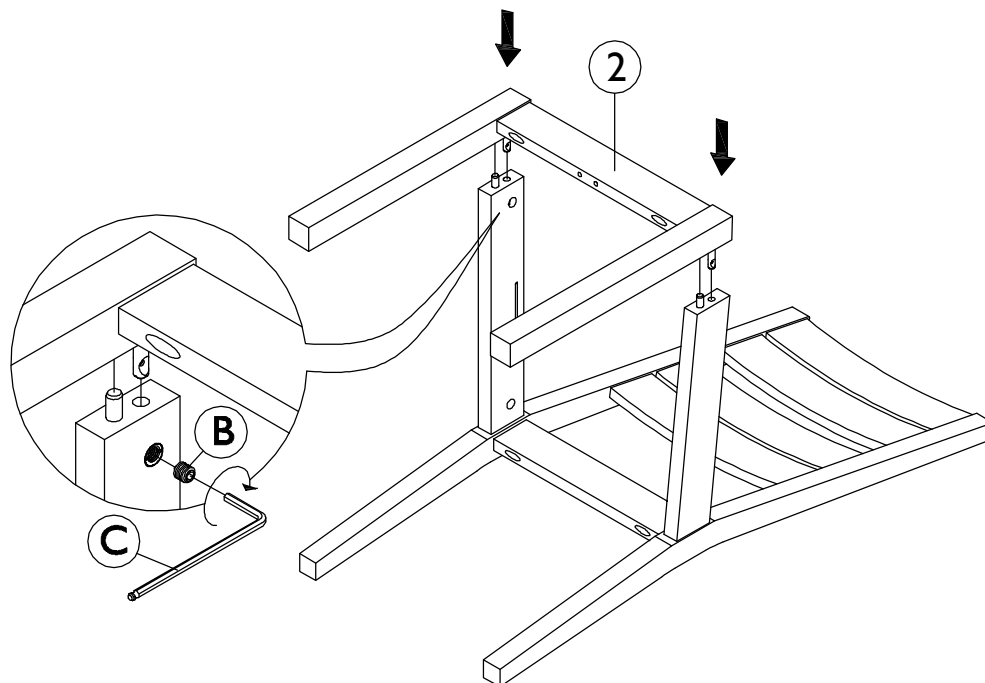

# Step By Step Assembly Instructions

- Step 4**
1. Lift the constructed chair frame up then place seat pad (5) under the constructed chair frame as shown.
  2. Lower the constructed chair frame onto seat pad (5) as shown.
  3. Insert 2x fitting (E) into the slots of the aprons both sides as shown.
  4. Ensure the holes on fitting (E) are aligned to the holes on seat pad (5) then secure seat pad (5) using 2x fitting (D) as shown. Use hexkey (F) to turn fitting (D) clockwise to fix.
- \* Repeat the complete process for the second chair.**

Fitting



D x 2



E x 2



F x 1

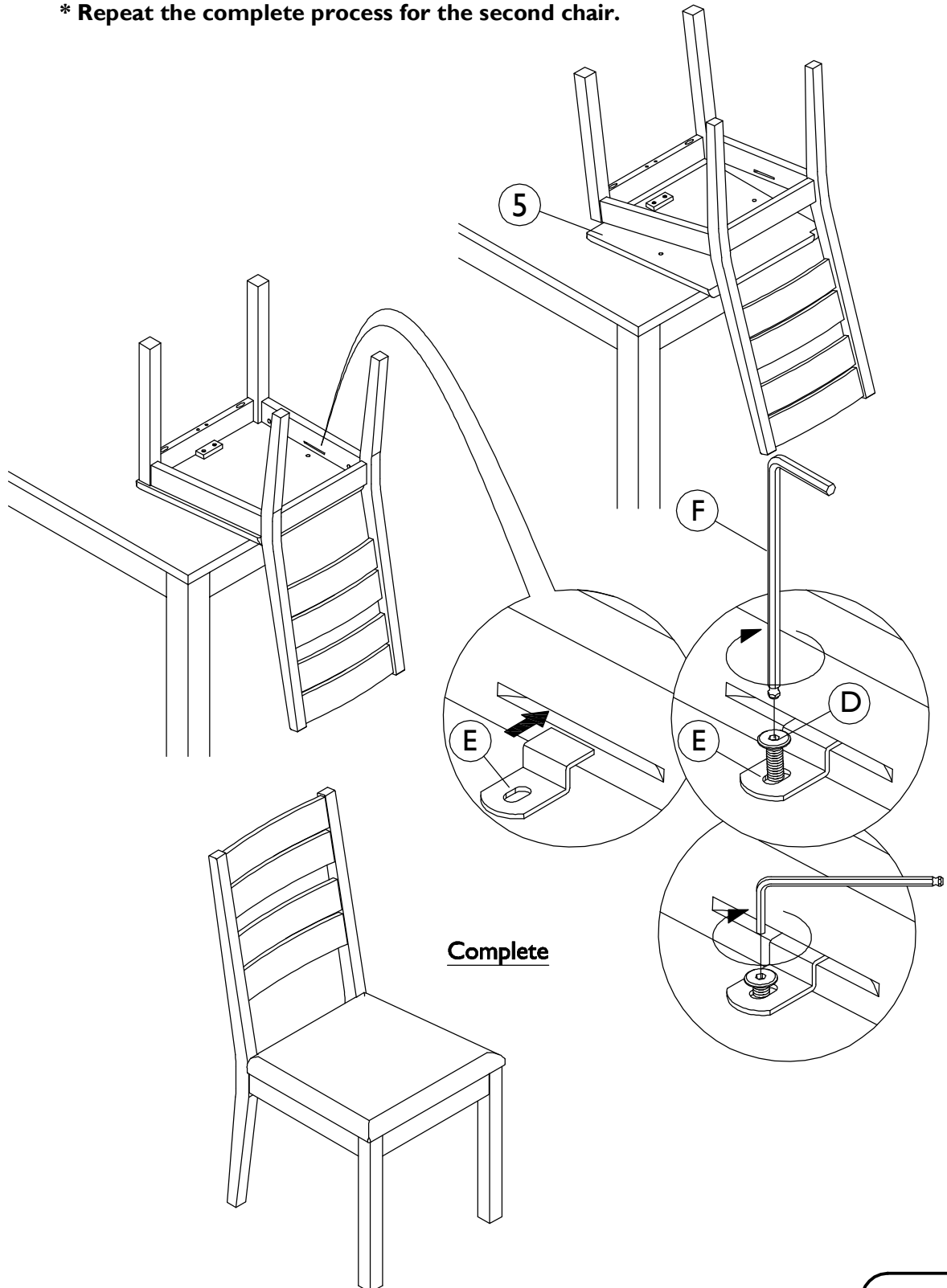

---

# Care and Maintenance

## Wood Furniture

Wood display different grain patterns depending on which way they cut - for example, the 'medullary ray' which can appear on oak furniture is a mark of good quality timber - these are just characteristics of the natural beauty of the wood. Some furniture is also deliberately aged and rustic.

Wood veneers also allow distinctive patterns to be created on flat surfaces, such as table tops and drawer fronts by the way silvers are arranged.

All timber surface will change colour and mellow over time. New furniture will initially vary in shade from items that have been previously purchased.

Our furniture will endure most temperatures in the home but it is best to avoid placing furniture next to heat sources such as radiators or fires or continued exposure to direct sunlight. Be particularly careful with solid wood as the lack of humidity caused by central heating can cause damage such as warping and splitting or cracking.

## How to care for your wood furniture

Furniture with frequent dusting will remove abrasive build up, which can damage furniture over time or painted surface should be dusted with a dry cloth.

Spray polishes are best avoided as they contain silicones which may spoil the furniture's surface when building up over time.

Make sure all surfaces are protected from heat and liquids by mats and coasters. Wipe up spills immediately and ensure that a mat or pad is placed under paper if you are writing.

Do not use a very wet cloth or allow any liquid to contact with the veneers for a long period of time as this can permanently damage the surface. Do not use any abrasive cleaner or harsh detergent as this can damage the surface of the veneers.

## Upholstered furniture

The upholstery should not be exposed for long periods to direct sunlight as this may cause fading and deterioration of the cover material. Protect from exposure to sources of heat such as radiators or open flames. It is recommended to give the upholstery a frequent vacuuming or light brushing.

It is very important to rub very gently to avoid colour change. This proper cleaning will prevent buildup of dust, soil and oils which can be damaging to the cover material.

In the event of spillage it is imperative to act quickly. Carefully soak up any excess liquid, ideally using the edge of a white paper towel, then dab gently with a fresh towel taking care to avoid soaking in or spreading of the remaining liquid.

It is advisable to seek professional help when serious stains occur or when an overall soiled condition has been reached.

### General warnings:

Never drag furniture when moving it, always lift it.

Periodically check all fixings to ensure none have come loose and re-tighten where necessary.

Please take care when handling or moving the furniture as careless handling may cause damage or injury.

Furniture can be dangerous if incorrectly assembled. Assembly should be carried out by a competent person.

No liability will be accepted for damage or injury caused by incorrectly installed or assembled furniture.

### Chair warning:

Never tilt the chair. Ensure the chair is always placed firmly on the ground.

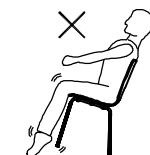

**PLEASE KEEP THESE INSTRUCTIONS FOR FUTURE REFERENCE**

Page : 6